

James Walker[®]

Walkersele[®] Radial Lip Seals

Issue 45.2



- *High-efficiency rotary lip seals*
- *Long-life bearing protection*
- *On-Site Joining for downtime savings*
- *1000s of standard sizes*
- *Custom-designed specials*

High Performance Sealing Technology



Introduction to Walkersele[®]



James Walker

James Walker is a dynamic global manufacturing organisation that supplies a vast range of specialised products and services to virtually every sector of industry.

We have more than 50 production, engineering, distribution and customer support facilities worldwide — backed by extensive IT networks, secure e-commerce systems, and logistics operations — to serve customers in over 100 countries.

Our world-leading areas of expertise are high performance fluid sealing, bolting technology and engineering plastics. These are mainly materials-led, and range from research, development and manufacture to product application and plant refurbishment.

Together with associated knowledge-based services, they help to keep industry running safely and efficiently, year after year.



Walkersele[®] — a worldwide reputation

Walkersele[®] is our well-proven family of radial lip seals for rotating shafts and rotary plant, such as:

- Gearboxes
- Rolling mills
- Marine propulsion units
- Wind turbines
- Hydropower
- Wave and tidal energy schemes
- Process mixers and centrifuges
- Conveyor systems
- Winding gear.

Many industries across the world rely on Walkersele to:

- Protect bearings
- Prevent ingress of water and other media
- Keep lubricant contaminant-free
- Prevent oil and grease from spoiling finished products.

Moreover, design engineers and plant operators rely on our pedigree in high performance sealing technology, with full technical back-up, to provide optimised solutions to their specific fluid sealing problems.



	Page		Page
Why you fit Walkersele®	4	Special features	25-27
Walkersele® selection	5-9	Walkersele® SpringSafe	25
Seven simple steps to Walkersele® selection	6-7	Walkersele® SpringCover	25
Performance Table 1: Maximum working pressure	6	Walkersele® with Dust Lip	25
Performance Table 2: Walkerseles with retaining plates	8	Walkersele® Shallowback designs	26
Performance Table 3: Self-retaining Walkerseles	9	Walkersele® Long Lip	26
Materials technology	10-11	Walkersele® with Ports & Grooves	26
Walkersele® materials	12-14	Endless-type Walkerseles	27
M1 — nitrile (NBR)	12	Split-type Walkerseles	27
M5 — butyl (IIR)	12	Walkersele® M1/D6 standard range — inch & metric	28-29
M6 — nitrile (NBR)	12	JW Chart 56 inch sizes	28
M8 — fluoroelastomer (FKM)	12	JW Chart 57 metric sizes	29
M9 — fluoroelastomer (FKM)	12	Walkersele® M6/D6 standard range — inch & metric	30-32
M11 — nitrile (NBR) for marine and power train duties	12	JW Chart 104 inch sizes	30
M12 — nitrile (NBR)	13	JW Chart 105 metric sizes	31
M13 — nitrile (NBR)	13	JW Chart 376 metric sizes to DIN 3760/BS ISO 6194-1	31-32
M22 — hydrogenated nitrile (HNBR) for wind turbines	13	Housing design & machining requirements	33-34
Millglide — hydrogenated nitrile (HNBR) for rolling mills	13	Walkersele® fitting techniques	35-38
Supaglide — hydrogenated nitrile (HNBR) for rolling mills	13	Operational considerations	39-41
Ultraglide — optimised hydrogenated nitrile (HNBR)	14	Multi-seal configurations	39
Aflas® — tetrafluoroethylene-propylene (FEPM)	14	Seal lubrication	39
Walkersele® designs	15-20	Eccentricity limits	40
Walkersele® D6 — most popular design	15	Lip support plates	40
Walkersele® D7 — pressure resistant	16	Shaft features — general requirements	40
Walkersele® D8 — for marine propulsion and processing	16	Shaft surfaces; Shaft hardness; Ceramic shafts	41
Walkersele® D1 — original design	17	Housing surfaces	41
Walkersele® D5 — compact design	17	Walkersele® storage	41
Walkersele® D4 — for slow rotary duties	17	Other rotary seal types	42
Walkersele® TBMS — for tunnel boring machines	18	End face seals or V-rings	42
Customised design & testing	19-20	Metal cased lip seals	42
Typical applications	21	James Walker in action	43-44
Walkersele® OSJ-2 for On-Site Joining	22-23	Industry-wide applications	45
Special arrangements for worn shafts	24	Information — Alphabetical index of products & materials	46
Walkersele® Cartridges	24	Technical guides	47
Spacer rings	24	James Walker worldwide support & distribution	48
Walkersele® Shaft Sleeves	24		

Why you fit Walkersele®

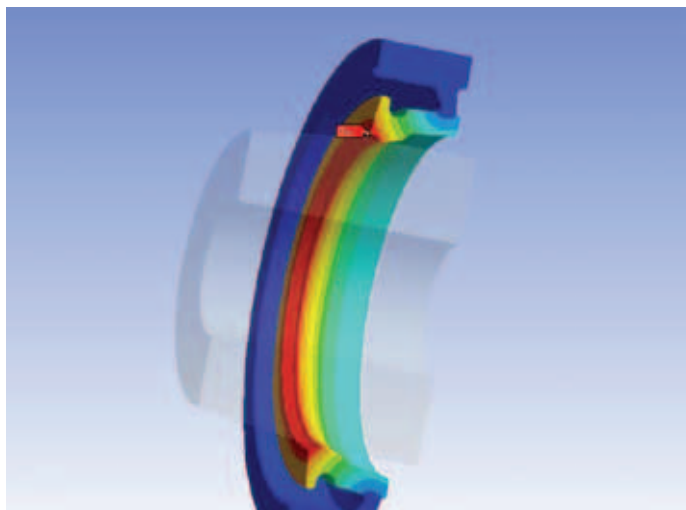

Higher efficiency — lower running costs

The primary role of a Walkersele® is to maintain lubricant within a bearing assembly. It will effectively:

- Extend bearing life and improve plant reliability.
- Cut maintenance costs and downtime.
- Reduce lubricant loss and costs.
- Help prevent lubricant-contamination of process fluid and/or the environment.
- Cut power consumption with low-friction running.
- Reduce corrosion caused by dissimilar metal interfaces.

When manufactured with a secondary lip, or fitted in a back-to-back configuration, Walkerseles will also:

- Prevent ingress of water, process media or solid contaminants to the bearing.
- Increase lubricant life by reducing contamination from external media.

Standard elastomer-proofed fabric back Walkerseles are manufactured with an interference fit within the housing bore. This puts the elastomer into compression on the shaft, rather than into tension as found on metal cased seals.

Seals with lips under tension around the shaft will generate more heat, and can wear more rapidly, than seals under compression. This compressive load provides a distinct advantage when a retaining plate is used.



Constant development & innovation

When our extensive standard ranges of Walkersele cannot solve a particular problem, we can custom design and manufacture a special lip seal that will (see pages 19-20). We often use state-of-the-art finite element analysis (FEA) to fine-tune the design, then extensively test the prototypes on static and dynamic rigs prior to field trials.

Over the past 60 years of Walkersele history, our constant programmes of research and development have introduced great improvements in materials and design for radial lip seals. This work enables Walkersele to meet current operational challenges:

- Severe mechanical conditions on giant offshore wind turbines.
- The hot and abrasive environment of high-speed rolling mills.
- Below the water line on marine propulsion systems and tidal energy schemes.

Flexible manufacturing

We have thousands of mould tools for Walkersele production, covering virtually all shafts of metric and inch standard sizes, plus hundreds of non-standard sizes. The list grows constantly.

Our flexible manufacturing regime enables us to produce Walkerseles to meet tight deadlines— and our *Express Service* is designed to meet industry's most urgent over-night demands.

At our Cockerthorpe facility in the UK, we have one of Europe's largest elastomeric moulding presses for making seals up to 2.2m OD (87 inch) in a single pass. But this does not limit the size of a Walkersele, as we mould to unlimited diameters using a special technique — the record stands at 11 m (36ft) diameter.

For customers in the USA, our Glenwood, Illinois, facility supplies a fast turn-round of Walkerseles using special temporary tooling that is ideal for short production runs and prototyping.

Walkersele® selection

Our Walkersele® family offers a wide range of standard material/design combinations to suit virtually all radial lip seal duties. To select the correct combination for a specific application, please see *Walkersele® selection* on pages 6 to 9.

Walkersele® designs in M1, M5, M9 or Ultraglide/Supaglide/Millglide materials

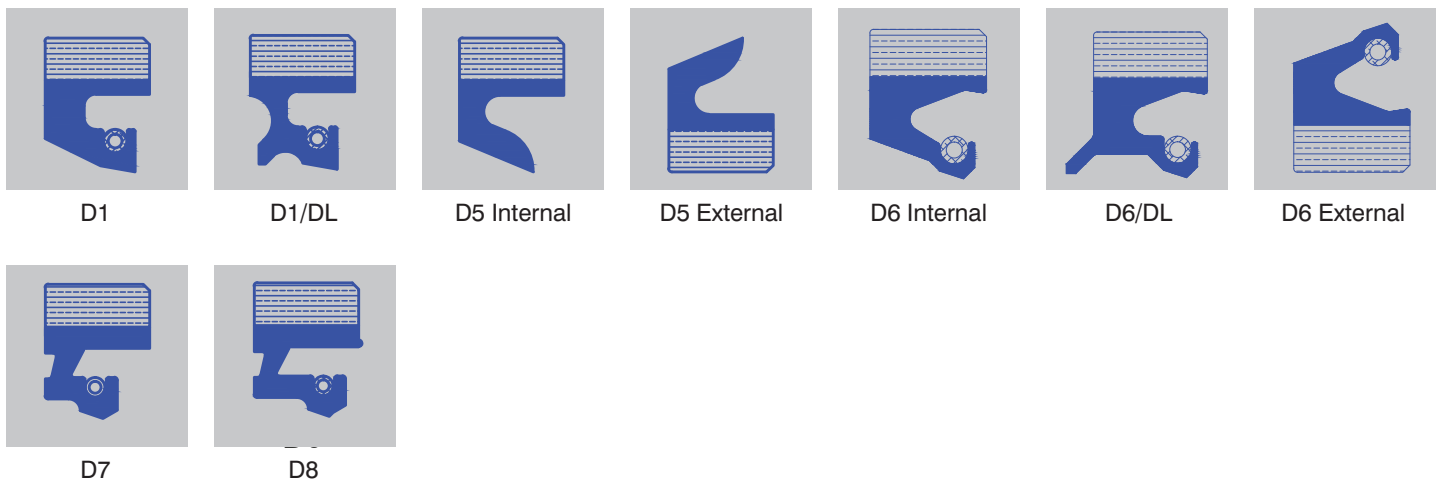

Walkersele® designs in M6 or Ultraglide/Supaglide/Millglide materials with 'M' backs

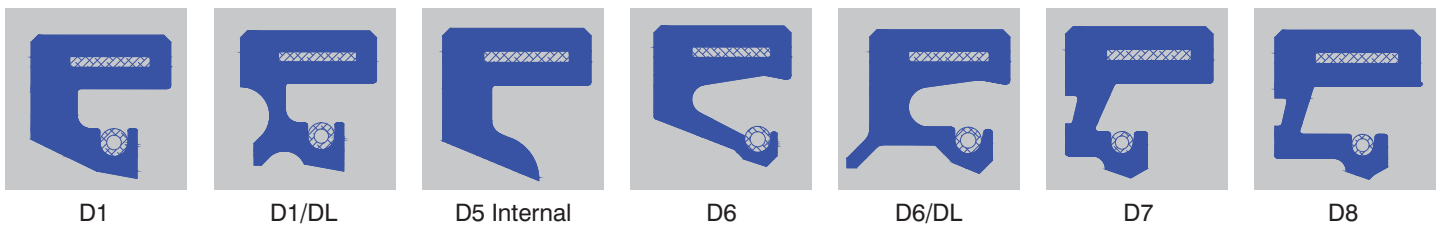

Walkersele® designs in M6, M8 or Ultraglide materials with 'S' backs



Other Walkersele® designs available

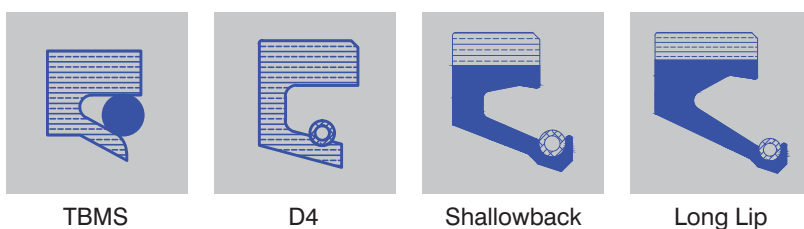

Note: These diagrams are for illustrative purposes only. Do not scale.

Walkersele® selection

Seven simple steps to Walkersele® selection

Walkersele® radial lip seals are identified:

- Firstly by their **Materials** of construction (M1, M8, etc)
- Then by their **Design** (D6, D7, etc).

Using this convention, typical designations are:

- **Walkersele M1/D7** and
- **Walkersele Ultraglide K/D6**.

To help you select the correct Walkersele for your application, please consider your seal requirements in the sequence outlined below.

Step 1: Maximum working pressure

Maximum working pressure is the primary parameter that determines the most suitable Walkersele design for a specific application. Please refer to *Performance Table 1*.

PERFORMANCE TABLE 1: MAXIMUM WORKING PRESSURES

Maximum working pressure	Walkersele® design recommendations
20kPa/0.2bar (3psi)	D6* or D6/DL
150kPa/1.5bar (21.75psi)	D8 with heel support
200kPa/2.0bar (29psi)	D6 with lip support plate
400kPa/4.0bar (58psi)	D7 with heel support
>400kPa/4.0bar (58psi)	Special D7 configurations — please consult our Technical Support Team

* For higher pressure applications with D6 on intermittent duties, please consult our Technical Support Team.

We recommend you use our Walkersele D6, D6/DL or D7 designs wherever possible for industrial duties, and our D8 for marine propulsion as well as industrial processing duties. Between them, they cover the vast majority of radial lip seal applications.

*(Note that we do **not** recommend using a seal with a pressure rating that is higher than actually required – eg, as a safety factor – as lip loads will be unnecessarily higher.)*

If these designs are unsuitable, please consider our alternatives, such as D1, D4, D5, TBMS, or a custom-designed seal.

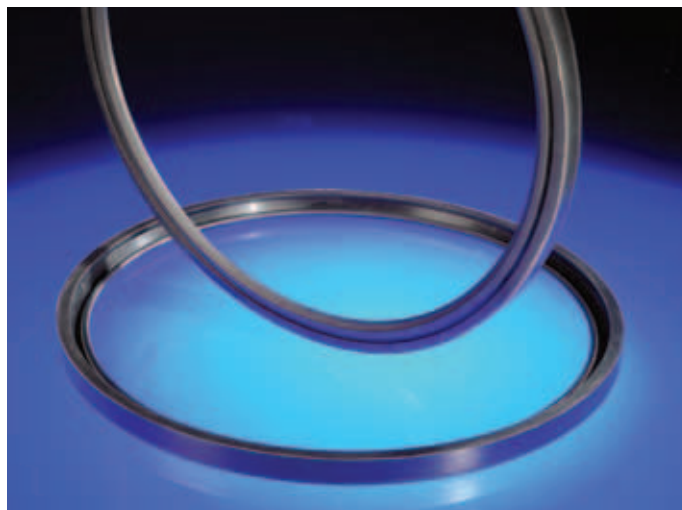

Step 2: Operational parameters

Determine the following parameters for your specific applications. *(Note that maximum pressure, velocity, and temperature ratings should not be applied simultaneously to a Walkersele – if in doubt, please consult our Technical Support Team for recommendations.)*

- **Maximum under-lip working temperature of seal.**
Note that under-lip temperature can be substantially higher (eg, by 30°C or 54°F), than the fluid media temperature.
- **Maximum shaft surface speed.**
- **Fluid media to be retained.**

Step 3: Seal retention method

Determine whether the seal will be **Retained** in its housing by a bolted plate, or **Self-retaining** in an open housing.

Step 4: Performance Tables 2 & 3

For **Retained** seals, refer to *Performance Table 2* on page 8. For **Self-retaining** seals, refer to *Performance Table 3* on page 9.

Cross-reference your suggested Walkersele design from Step 1, with maximum working temperature and surface speed to find the Walkersele types that most closely match your requirements.

Walkersele® selection

**Step 5: Material compatibility**

Check that the seal material/s are compatible with your fluid media by referring to *Walkersele® materials* on pages 12 - 14. If in doubt, please consult our Technical Support Team.

Step 6: Walkersele® operational features

Please consider and check the availability of the following options for your combinations of Walkersele Materials/Design.

- **Endless** or **Split** type seals. Endless types offer maximum sealing integrity, and can be used in an open housing when in **Self-retaining** form. Split types are swifter and easier to install during maintenance as plant strip-down is minimised.

However, abutting seal ends is NOT recommended when:

- a) Shaft dynamics are severe.
- b) High integrity sealing is required.
- c) Oil levels are above the centre line of the shaft.

When any of these conditions apply, please consider using our **Walkersele OSJ-2**.

(Note that Walkersele D7 and D8 designs are supplied only as endless or OSJ-2 types.)

- **Walkersele OSJ-2** for On-Site Joining of split-type seals. This technique combines cost-effective maintenance with greatly reduced down-time, and provides the sealing integrity of an endless-type seal (pages 22 - 23).
- **Walkersele SpringSafe**: to keep the lip-energising spring securely in place during installation and operation (page 25).
- **Walkersele with Ports & Grooves**: to distribute lubricant to the lips of seals working in back-to-back formation (page 26).

- **Walkersele SpringCover**: provides external and internal corrosion protection for spring-energised lip seals (page 25)
- **Walkersele with Dust Lip** (eg, D6/DL): standard designs with an auxiliary dust lip incorporated to prevent the ingress of contaminants in aggressive environments (page 25).
- **Walkersele Shallowback**: D6 and D7 designs with reduced depth at the back, and flexible, extended lips, for use where housing space is limited (page 26).
- **Walkersele Long Lip**: for sealing slowly rotating shafts that suffer a high degree of eccentricity (page 26).

Step 7: Ordering your Walkersele®

Please check the size of Walkersele you need against our Standard Ranges (pages 28 - 32) then call to your local James Walker contact for advice on product suitability and delivery. If the seal you want is not listed, please refer to your James Walker contact, as we have thousands of Walkersele moulds including a vast number of non-standard sizes.

Walkersele® selection

PERFORMANCE TABLE 2: WALKERSELES FOR USE WITH RETAINING PLATES

Walkersele® type	Materials	Maximum under-lip temperature*	Maximum constant surface speed*	Comments
M1/D6	Nitrile (NBR) + proofed fabric	120°C (248°F)	15m/s (2953fpm)	Most popular Walkersele for industrial duties.
M1/D6/DL	Nitrile (NBR) + proofed fabric	120°C (248°F)	15m/s (2953fpm)	M1/D6 with auxiliary dust lip.
M1/D7	Nitrile (NBR) + proofed fabric	120°C (248°F)	12m/s (2362fpm)	Popular, well-proven seal with pressure-resistant lip.
M1/D8	Nitrile (NBR) + proofed fabric	120°C (248°F)	15m/s (2953fpm)	Pressure resistant with lower lip loading.
M5/D6	Butyl (IIR) + proofed fabric	120°C (248°F)	5m/s (984fpm)	For specific chemical compatibilities.
M5/D6/DL	Butyl (IIR) + proofed fabric	120°C (248°F)	5m/s (984fpm)	M5/D6 with auxiliary dust lip.
M5/D7	Butyl (IIR) + proofed fabric	120°C (248°F)	5m/s (984fpm)	Pressure resistant lip + specific chemical compatibilities.
M9/D6	Fluoroelastomer (FKM) + aramid/glass fabric	200°C (392°F)	25m/s (4922fpm)	For high temperatures & speeds, where chemical compatibility is important.
M9/D6/DL	Fluoroelastomer (FKM) + aramid/glass fabric	200°C (392°F)	25m/s (4922fpm)	M9/D6 with auxiliary dust lip.
M9/D7	Fluoroelastomer (FKM) + aramid/glass fabric	200°C (392°F)	20m/s (3937fpm)	Pressure resistant lip + high temperatures, speeds & chemical resistance.
M9/D8	Fluoroelastomer (FKM) + aramid/glass fabric	200°C (392°F)	25m/s (4922fpm)	Pressure resistance with lower lip loading + high temperatures, speeds & chemical resistance.
M11/D6	Nitrile (NBR) + aramid/glass fabric	120°C (248°F)	15m/s (2953fpm)	For marine duties & other water-based applications.
M11/D7	Nitrile (NBR) + aramid/glass fabric	120°C (248°F)	12m/s (2362fpm)	For marine duties & other water-based applications.
M11/D8	Nitrile (NBR) + aramid/glass fabric	120°C (248°F)	15m/s (2953fpm)	For marine duties & other water-based applications.
M12/D6	Nitrile (NBR) + proofed fabric	110°C (230°F)	15m/s (2953fpm)	Material for lower temperature duties.
M13/D6	Nitrile (NBR) + aramid/glass fabric	110°C (230°F)	15m/s (2953fpm)	Material for lower temperature duties.
M22/D6	Specially formulated HNBR + aramid/glass fabric	150°C (302°F)	15m/s (2953fpm)	For wind turbines.
Millglide K/D6	Reformulated HNBR + aramid/glass fabric	150°C (302°F), or 170°C (338°F) in oil	15m/s (2953fpm)	The cost effective choice for rolling mills, where assured performance is needed to fulfil maintenance regimes.
Supaglide K/D6	Reformulated HNBR + aramid/glass fabric	150°C (302°F), or 170°C (338°F) in oil	25m/s (4922fpm)	For rolling mills, where improved performance and wear resistance are needed at higher running speeds.
TBMS	Nitrile (NBR) proofed fabric	120°C (248°F)	2m/s (394fpm)	Tunnel boring machine seal for harsh underground duties.
Ultraglide K/D6	Reformulated HNBR + aramid/glass fabric	150°C (302°F), or 170°C (338°F) in oil	20m/s (3937fpm)	Optimised material for greatly extended working life under high speed and high temperature conditions.
Ultraglide K/D7	Reformulated HNBR + aramid/glass fabric	150°C (302°F), or 170°C (338°F) in oil	15m/s (2953fpm)	With pressure resistant lip. For extended working life under high temperature conditions.

* Note that maximum temperature, speed and pressure ratings may not necessarily be applied simultaneously to a Walkersele® — please consult our Technical Support Team for recommendations.

Other, less common, combinations of material and Walkersele® design are also available: please consult our Technical Support Team.

Walkersele® selection

PERFORMANCE TABLE 3: SELF-RETAINING WALKERSELES

Walkersele® type	Materials	Maximum under-lip temperature*	Maximum constant surface speed*	Comments
M6/D6	Nitrile (NBR) + stainless steel band	120°C (248°F)	12m/s (2362fpm)	Most popular self-retaining Walkersele.
M6/D6/DL	Nitrile (NBR) + stainless steel band	120°C (248°F)	12m/s (2362fpm)	M6/D6 with auxiliary dust lip.
M6/D7	Nitrile (NBR) + stainless steel band	120°C (248°F)	10m/s (1969fpm)	Well-proven seal with pressure-resistant lip.
M6/D8	Nitrile (NBR) + stainless steel band	120°C (248°F)	12m/s (2362fpm)	Pressure resistant, with lower lip-loading.
M8/D6	Fluoroelastomer (FKM) + stainless steel band	200°C (392°F)	20m/s (3937fpm)	For high temperatures and speeds where chemical compatibility is important.
M8/D6/DL	Fluoroelastomer (FKM) + stainless steel band	200°C (392°F)	20m/s (3937fpm)	M8/D6 with auxiliary dust lip.
M8/D7	Fluoroelastomer (FKM) + stainless steel band	200°C (392°F)	18m/s (3543fpm)	With pressure-resistant lip; for high temperatures, high speeds, and chemical compatibility.
M8/D8	Fluoroelastomer (FKM) + stainless steel band	200°C (392°F)	20m/s (3937fpm)	For high temperatures and speeds where chemical compatibility is important.
Millglide D6/M	Reformulated HNBR + stainless steel band	150°C (302°F), or 170°C (338°F) in oil	12m/s (2362fpm)	The cost effective choice for rolling mills, where assured performance is needed to fulfil maintenance regimes.
Supaglide D6/M	Reformulated HNBR + stainless steel band	150°C (302°F), or 170°C (338°F) in oil	20m/s (3937fpm)	For rolling mills, where improved performance and wear resistance are needed at higher temperatures and running speeds.
Ultraglide D6/M	Reformulated HNBR + stainless steel band	150°C (302°F), or 170°C (338°F) in oil	15m/s (2953fpm)	Optimised material for greatly extended working life and high temperature conditions.
Ultraglide D7/M	Reformulated HNBR + stainless steel band	150°C (302°F), or 170°C (338°F) in oil	15m/s (2953fpm)	With pressure resistant lip. For extended working life and high temperature conditions.

* Note that maximum temperature, speed and pressure ratings may not necessarily be applied simultaneously to a Walkersele — please consult our Technical Support Team for recommendations.

Other, less common, combinations of material and Walkersele® design are also available: please consult our Technical Support Team.

Materials technology

It is essential that your Walkersele® is manufactured from materials that are:

- Chemically compatible with the media to be sealed.
- Stable at the required working temperature. Note that the seal's under-lip temperature can be substantially higher — by 30°C (54°F) or more — than that of the fluid being contained.
- Wear resistant at the operating conditions.
- Suitable for your operating speed.

The importance of elastomer compounding

Although many manufacturers use the same base polymers for their elastomeric compounds and seals, the resulting products may perform in significantly different ways — sometimes as disparate as short-term failure against long-term service.

A base polymer is made into an engineering elastomer through the addition of a multitude of compounding chemicals. It is the nature and combination of these chemicals that define the characteristics of an elastomer.

In excess of 20 classes of compounding ingredients exist. These range from reinforcing fillers, curatives, accelerators, protectants, coupling agents and fire retardants, through to extenders and processing aids — enabling an almost infinite variety of grades to be compounded.

Seal users and specifiers need to satisfy themselves that their suppliers operate a no-compromises policy with regard to compounding, using only the highest quality raw materials purchased to rigorous specifications, then judiciously compounded to give optimum properties.

It is easy to dilute expensive specialised materials with cheaper ingredients to lower the final cost of a compound, or to add large quantities of processing aids that ease production. These policies often lead to impaired performance.

Overview of elastomers

We commonly use five generic elastomer types for the manufacture of Walkersele radial lip seals.

- Nitrile (NBR).
- Hydrogenated nitrile (HNBR).
- Butyl (IIR) – isobutene-isoprene.
- Fluoroelastomer (FKM).
- Tetrafluoroethylene/propylene dipolymers (FEPM) eg, Aflas®.

Nitrile (NBR)

Nitrile rubbers are good, general-purpose, oil/fuel resistant materials that are much less expensive than more complex high-performance elastomers. They offer good resilience for high integrity sealing in general applications.

Typical temperature range: -30°C to +120°C (-22°F to +248°F). Low temperature grades can operate down to -50°C (-58°F).

They are manufactured by the copolymerisation of butadiene and acrylonitrile. The acrylonitrile content has by far the most profound effect on the properties of a vulcanised nitrile rubber, influencing such characteristics as oil resistance and low temperature flexibility.

Hydrogenated nitrile (HNBR)

These materials have the excellent oil/fuel resistance of NBR, combined with superior mechanical properties, improved chemical resistance, better weatherability, better thermal capability, and outstanding abrasion resistance.

In general, HNBR grades tolerate higher surface speeds and temperatures, and offer longer working lives for rotary seals in abrasive environments, than NBR materials.

Typical temperature range: -25°C to +150°C, or +170°C in oil (-13°F to +302°F, or +338°F in oil). Lower minimum or higher maximum temperatures can be achieved.

Hydrogenated nitrile is derived from conventional nitrile. It is produced by a process that hydrogenates the unsaturation (carbon double bonds) in the butadiene unit of the polymer.

Butyl (IIR) – isobutene-isoprene

IIR compounds display low permeability to gases. They also have excellent resistance to ozone, weathering, hot and cold water and steam. Resistance to many chemicals is good, including acids, alkalis, salt solutions, alcohols, glycols and silicone oils. However, it has very poor resistance to mineral oils and hydrocarbon fuels.

Typical temperature range: -35°C to +120°C (-31°F to +248°F).

IIR is produced by copolymerising isobutylene in solution with low concentrations of isoprene. Both isoprene and isobutylene are usually obtained from natural gas or the lighter fractions of petroleum.

Materials technology

Fluoroelastomer (FKM)

Fluoroelastomers offer excellent resistance to oils, fuels, synthetic lubricants, many mineral acids and a vast range of other fluids. They have a higher temperature capability than NBR and HNBR grades.

Typical temperature range: -20°C to +230°C (-4°F to +446°F). Lower minimum temperatures can be achieved.

Thermal and chemical resistance are functions of fluorine level and cure system (but poor compounding can ruin the best elastomer). To get the optimum properties, including mechanical in addition to thermal and chemical resistance, we make our fluoroelastomer Walkerseles from terpolymer compounds.

There are three basic families of fluoroelastomer:

- Dipolymer; containing two components.
- Terpolymer; with three components – as typically used in Walkersele manufacture.
- Tetrapolymer; with four components.

Fluorine content varies from 65% in dipolymers to over 70% in some tetrapolymers.

Tetrafluoroethylene/propylene dipolymers (FPM) eg, Aflas®

FPM compounds have resistance to oils, lubricants, and some fuels, approaching that of fluoroelastomer dipolymers. They also have excellent resistance to ozone/weathering, steam and radiation. Overall chemical resistance is good.

Typical temperature range: +5°C to +200°C, or +260°C in steam (+41°F to +392°F, or +500°F in steam).

Fluorine content is around 56%, with the synergy between the monomer units resulting in a very useful, if specialised, material.

Standard & customised materials

All our elastomer-based material grades featured on the following pages have been specially developed for radial lip seal duties.

We compound all the elastomers in-house on a state-of-the-art internal mixer to an exacting regime with total traceability. Each batch of compound is subjected to rigorous testing and statistical process control before being converted to the final product.

When our standard materials are unsuitable for your application, we have the capability to tailor a compound to meet your specific operational requirements, typically for:

- Higher or lower temperature duties.
- Additional ozone resistance.
- Additional abrasion resistance.
- Eco-friendly fluid compatibility.
- Lower power consumption.

Technical advice

If you have any special material requirements, or want advice on materials selection, please contact our Technical Support Team.



Quality assured in-house compounding of high performance elastomers

Walkersele® materials

M1 — nitrile (NBR)

Description: This is our most popular material for the majority of Walkersele® applications. It suits housings fitted with retaining plates.

Media compatibility: Suitable for duties with water and the majority of oils and greases.

Seal construction: Flexible back of nitrile-proofed fabric, with lip of 80 IRHD nitrile rubber.

Maximum under-lip temperature: 120°C (248°F) constant.

Maximum surface speed: 15m/s (2953fpm) with D6 and D8 designs, or 12m/s (2362fpm) with D7 design.

M5 – butyl (IIR)

Description: Often used with media where butyl is required for chemical compatibility. It suits housings fitted with retaining plates.

Media compatibility: Resistant to silicone oils and greases, ozone, hot and cold water, acids, alkalis, salt solutions, alcohols and glycols. It must NOT be used with mineral based oils or greases.

Seal construction: Flexible back of butyl-proofed fabric, with lip of 70 IRHD butyl.

Maximum under-lip temperature: 120°C (248°F) constant.

Maximum surface speed: 5m/s (984fpm) with both D6 and D7 designs.

M6 — nitrile (NBR)

Description: This is our most popular material for self-retaining seals installed in open housings.

Media compatibility: Suitable for duties with water and the majority of oils and greases.

Seal construction: Moulded in nitrile rubber, with a stainless steel band encapsulated in its back.

Maximum under-lip temperature: 120°C (248°F) constant.

Maximum surface speed: 12m/s (2362fpm) with D6 and D8 designs, or 10m/s (1969fpm) with D7 design.

M8 — fluoroelastomer (FKM)

Description: For high working temperatures, or where fluoroelastomer is needed for chemical compatibility. Suitable for self-retaining seals installed in open housings.

Media compatibility: Excellent resistance to all lubricating oils, fuels, air, water and dilute acids.

Seal construction: Moulded in fluoroelastomer, with stainless steel band located in its back.

Maximum under-lip temperature: 200°C (392°F) constant.

Maximum surface speed: 20m/s (3937fpm) with D6 and D8 designs, or 18m/s (3543) with D7 design.

M9 — fluoroelastomer (FKM)

Description: For high working temperatures, or where fluoroelastomer is needed to accommodate high operating speeds or chemical compatibility. It suits housings fitted with retaining plates.

Media compatibility: Excellent resistance to all lubricating oils, fuels, air, water and dilute acids.

Seal construction: Flexible back of fluoroelastomer-proofed aramid/glass fabric, with lip of fluoroelastomer.

Maximum under-lip temperature: 200°C (392°F) constant.

Maximum surface speed: 25m/s (4922fpm) with D6 and D8 designs, or 20m/s (3937fpm) with D7 design.

M11 — nitrile (NBR) for marine propulsion/power-train duties

Description: This material has been specially developed for marine duties and industrial applications where it will be submerged in salt water or fresh water. It suits housings fitted with retaining plates.

Media compatibility: Suitable for duties with water and the majority of oils and greases.

Seal construction: Flexible back of nitrile-proofed aramid/glass fabric, with lip of 80 IRHD nitrile rubber.

Maximum under-lip temperature: 120°C (248°F) constant.

Maximum surface speed: 15m/s (2953fpm) with D6 and D8 designs, or 12m/s (2362fpm) with D7 design.

Walkersele® materials

M12 — nitrile (NBR)

Description: For duties where its lower temperature capability is beneficial. It suits housings fitted with retaining plates.

Media compatibility: Suitable for duties with water and the majority of oils and greases.

Seal construction: Flexible back of nitrile-proofed fabric, with lip of 70 IRHD nitrile rubber.

Under-lip temperature range:

From -48°C (-54°F) up to +110°C (+230°F).

Maximum surface speed: 15m/s (2953fpm) with D6 design.

M13 — nitrile (NBR)

Description: Similar to M11, but recommended for duties where its lower temperature capability is beneficial. It suits housings fitted with retaining plates.

Media compatibility: Suitable for duties with water and the majority of oils and greases.

Seal construction: Flexible back of nitrile-proofed aramid/glass fabric, with lip of 70 IRHD nitrile rubber.

Under-lip temperature range:

From -48°C (-54°F) up to +110°C (+230°F).

Maximum surface speed: 15m/s (2953fpm) with D6 design.

M22 — hydrogenated nitrile (HNBR) for wind turbines

Description: A specially formulated HNBR for long-term duties on main shafts and gearboxes of wind turbines operating in harsh environments. It suits housings fitted with retaining plates.

Media compatibility: Excellent resistance to a wide range of mineral and synthetic lubricants.

Seal construction: Flexible back of HNBR-proofed aramid/glass fabric, with HNBR lip of 80 IRHD.

Under-lip temperature range: From -25°C (-13°F) up to +150°C (+302°F).

Maximum surface speed: 15m/s (2953fpm) with D6 design.

Millglide K & M — hydrogenated nitrile (HNBR) for rolling mills

Description: These materials are cost-effective choices for rolling chocks and heavy-duty gearboxes in the metallurgical sector. Based on reformulated HNBR, they offer a significant improvement over nitrile (NBR) where assured performance is needed to fulfil maintenance regimes. **Millglide K** suits housings fitted with retaining plates; **Millglide M** is suitable for self-retaining seals installed in open housings.

Media compatibility: Excellent resistance to a wide range of mineral and synthetic lubricants.

Seal construction: **Millglide K** has a flexible back of HNBR-proofed aramid/glass fabric, with an HNBR lip of 80 IRHD. **Millglide M** is moulded in HNBR of 80 IRHD, with a stainless steel band encapsulated in its back.

Maximum under-lip temperature: 150°C (302°F), or 170°C (338°F) in oil.

Maximum surface speed: **Millglide K**; 15m/s (2953fpm) with D6 design. **Millglide M**; 12m/s (2362m/s) with D6 design.

Typical applications: Rolling chocks and heavy-duty gearboxes.

Supaglide K & M — hydrogenated nitrile (HNBR) for higher speed rolling mills

Description: Based on reformulated, high-strength HNBR. Special additives extend the material's performance for use in abrasive environments on higher-speed rolling chocks.

Supaglide K suits housings fitted with retaining plates; **Supaglide M** is suitable for self-retaining seals installed in open housings.

Media compatibility: Excellent resistance to a wide range of mineral and synthetic lubricants.

Seal construction: **Supaglide K** has flexible back of reformulated HNBR-proofed aramid/glass fabric, with lip of 80 IRHD reformulated HNBR. **Supaglide M** is moulded in 80 IRHD reformulated HNBR with a stainless steel band encapsulated in its back.

Maximum under-lip temperature: 150°C (302°F), or 170°C (338°F) in oil.

Maximum surface speed: **Supaglide K**; 25m/s (4922fpm) with D6 design. **Supaglide M**; 20m/s (3937m/s) with D6 design.

Walkersele® materials

Ultraglide K & M — hydrogenated nitrile (HNBR) for longer working life

Description: Ultraglide is based on a reformulated HNBR that extends by up to six times the working life of a Walkersele® running in high temperature environments. **Ultraglide K** suits housings fitted with retaining plates. **Ultraglide M** is suitable for self-retaining seals installed in open housings.

Media compatibility: Excellent resistance to all lubricating oils, fuels, air, hot and cold water, dilute acids and alkalis.

Seal construction: **Ultraglide K** has a flexible back of HNBR-proofed aramid/glass fabric, with lip of special low-friction, low-wear HNBR. **Ultraglide M** is moulded in 80 IRHD low-friction, low-wear HNBR, with a stainless steel band encapsulated in its back.

Maximum under-lip temperature: 150°C (302°F) constant, and 170°C (338°F) in oil.

Maximum surface speed: **Ultraglide K**; up to 20m/s (3937fpm) with D6 design, or up to 15m/s (2953fpm) with D7 design.

Ultraglide M; 15m/s (2953fpm) with both D6 and D7 designs.

Please note that other materials are available for specific Walkersele® requirements, including the Aflas® grade as shown alongside.

Aflas® — tetrafluoroethylene/propylene (FEPM)

Description: This material uses our AF90/LS compound for duties in highly aggressive chemical environments with steam — eg, chemical pulping lines — or radioactive areas. It suits housings fitted with retaining plates.

Media compatibility: Excellent resistance to aggressive bleaching agents (particularly chlorine-free types), and high-temperature water/steam. Also resistant to strong acids, oils, lubricants and some fuels, weathering and ozone.

Seal construction: Construction method is selected to suit specific applications. A modified Walkersele® D1 design is used for chemical pulping lines, with an unchamfered lip to prevent build-up of abrasive pulp, and ports and grooves for inter-seal lubrication. D6 and D7 designs can be used for duties beyond chemical pulping lines.

Maximum under-lip temperature: Please consult our Technical Support Team.

Maximum surface speed: Please consult our Technical Support Team.

Walkersele® designs

Walkersele® designs evolve constantly to meet the needs of modern rotary plant working in fast moving industrial and marine environments.

James Walker Technology Centre works at the frontiers of:

- Sealing technology.
- Materials technology.
- Tribology.
- Hydraulic fluid film theory.

Its aim is to ensure that Walkersele products are ready to meet the exacting demands of tomorrow's plant and equipment before they arise.

Spring energised lips

Most Walkersele designs use a toroidal spring that lightly energises the flexible lip to ensure efficient sealing.

Walkerseles differ from many other manufacturers' lip seals in that they usually have no exposed metal components apart from the stainless steel spring. However, by using our **SpringSafe** feature (page 25) even the toroidal spring can be safely cured into the lip-groove in our most popular designs if exposed metal is unacceptable.

Housing types — Retained and Self-retaining

Most Walkersele designs are manufactured in two versions:

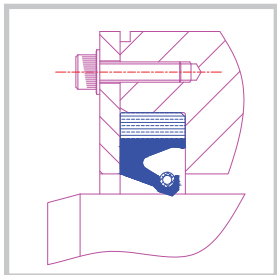

Retained: These have an elastomer-proofed fabric back for installation in housings fitted with retaining plates. The lip and back sections are moulded together during manufacture to form a high strength intimate bond.

Retained seals are supplied endless, or as split-types for ease of fitting.

Our **Walkersele® OSJ-2** technique (pages 22 - 23) provides the ease of fitting of split-types combined with the sealing integrity of endless types.

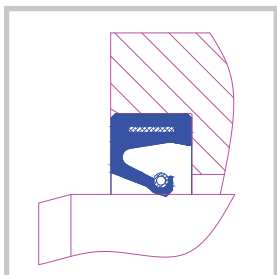

Self-retaining: These have a solid back of the same moulded elastomer material as the lip. A flexible steel band is incorporated in the solid elastomer back. They are supplied only as endless types.

Walkerseles of this construction can normally be installed in open housings without retaining plates. (The exceptions are our D7 and D8

designs that operate under pressure and require heel support when fitted facing inboard to seal an internal pressure media.)

For full housing details on Walkerseles, see pages 33 - 34.

Walkersele® D6 — most popular design

This is the standard Walkersele® design. It is suitable for the vast majority of bearing protection and other radial lip seal applications across most sectors of industry.



Special features

- Lip profile minimises heat generation and shaft wear.
- Geometry gives lip flexibility to accommodate shaft eccentricity.
- Fabric-backed (retained) versions can be supplied as split-types, and as **Walkersele® OSJ-2** (pages 22 - 23) for On-Site Joining.
- Operates at up to 20kPa/0.2bar (3psi) pressure differential, or up to 200kPa/2bar (29psi) with **lip support plate** (see page 40).

Walkersele® D6 availability — standard ranges

JW Charts 56 and 57 (pages 28 - 29) cover standard ranges of our Walkersele M1/D6 fabric-backed (retained) version in inch and metric sizes respectively. These can be supplied in endless or split form — note the different part numbers on charts.

JW Charts 104 and 105 (pages 30 - 31) cover our self-retaining Walkersele M6/D6 seals in inch and metric sizes respectively.

JW Chart 376 (pages 31 - 32) covers self-retaining Walkersele M6/D6/M seals conforming to DIN 3760 and the equivalent BS ISO 6194 standards, as previously covered by BS 1399.

Walkersele® D6 availability — non-standard sizes

Existing tools — we have thousands of Walkersele moulds, including a vast number for non-standard sizes. If the D6 size you want is not on the JW Charts, please contact us to check mould availability. If we have a suitable tool, your seal can be supplied on short delivery time without tooling charges.

Specials — new tools are swiftly made in-house for non-standard sizes. In such cases a tooling charge will be applied. Seals for shaft diameters from 25mm to 2200mm (1 inch to 87 inch) are produced by conventional moulding methods. Sizes above this, and up to unlimited diameter, are manufactured using our highly developed mould-joining technique.

Walkersele® designs

Walkersele® D7 — pressure resistant

This is our second most popular design. Its robust profile with a pressure-resistant lip suits applications where there is a pressure differential up to 400kPa, especially in the processing industries.



Special features

- Operates at up to 400kPa/4bar (58psi) pressure differential. To achieve this, the heel of the seal lip must always be supported.
- No costly profiled lip-support plates are needed.
- Self-retaining D7 seals can be used in open housings when sealing external fluids — but a simple retaining plate is needed to support the heel of the seal lip when seal is facing inboard.
- Robust lip maintains sealing contact on shafts suffering slight misalignment or eccentricity.
- Fabric-backed (retained) versions can be supplied as **Walkersele® OSJ-2** (pages 22 - 23) for On-Site Joining.

Walkersele® D7 availability

Existing tools — our tool library covers all popular D7 sizes and many non-standards. Please contact us to check mould availability. Where we have a suitable tool, your seal will be supplied on short delivery time without tooling charges.

Specials — new tools are swiftly made in-house for non-standard sizes. In such cases a tooling charge will be applied. Seals for shaft diameters from 25mm to 2200mm (1 inch to 87 inch) are produced by conventional moulding methods. Sizes above this, and up to unlimited diameter, are manufactured using our highly developed mould-joining technique.

Walkersele® D8 — for marine propulsion & industrial processing

Walkersele® D8 is a recent addition to our range. Introduced initially for marine propulsion applications, its trouble-free operation has been proven by extensive sea trials on working vessels, backed by in-house dynamic testing to extreme levels. It is also recommended for industrial processing duties where pressure is slightly higher than D6 can accommodate, but lip flexibility is still needed to follow the eccentricity of a shaft.



Special features

- New lip geometry of D8 withstands higher pressure differentials than our D6 design, with lower lip loading than our D7 design.
- Operates at up to 150kPa/1.5bar (21.75psi) pressure differential. The base of the seal must be fully supported for pressures greater than 20kPa/0.2bar (3psi).
- Accommodates shaft eccentricity of 3.0mm TIR (typical maximum) dependent on shaft diameter and speed. Note that a modified retaining plate and/or lip support plate may be needed when shaft eccentricity occurs: please consult our Technical Support Team.
- Robust lip of D8 design has been validated on marine duties where operating conditions have included shock and vibration.
- Recommended for marine propulsion units, azimuth thrusters, large diameter swivels, stern gland seals and flooded gearboxes. Also for process equipment — onshore, as well as offshore and marine.
- Fabric-backed (retained) versions can be supplied as split-types and as **Walkersele® OSJ-2** (pages 22 - 23) for On-Site Joining.
- Cartridge seals can be custom-designed.

Walkersele® D8 availability

We recommend that D8 be manufactured in our M11 nitrile-based material (see page 12) for marine duties. This material is resistant to marine industry media, and is suitable for housings with retaining plates.

Existing tools — we are currently building a library of mould tools for D8 sizes. Please contact us to check mould availability. If we have a suitable tool, your seal can be supplied on short delivery time. New tools are swiftly made in-house.

Walkersele® designs

Walkersele® D1 — our original design

This non-chamfered lip design has been found to provide significant advantages on slow-running abrasive applications, such as chemical pulping lines in the pulp and paper industry, where its square edge prevents fibre ingress.

**Special features**

- Aflas® version, with ports and grooves, provides long-term protection for bearings of dewatering presses at pulp works (see page 14).
- Fabric-backed (retained) versions can be supplied as split-types, and as Walkersele® OSJ-2 (pages 22 - 23) for On-Site Joining.

Walkersele® D1 availability

Existing tools — we hold many tools for this original standard design, plus specific sizes for the modified Aflas version. Please contact us to check mould availability. Where we have a suitable tool, your seal will be supplied on short delivery time without tooling charge.

Specials — new tools are swiftly made in-house for non-standard sizes. In such cases a tooling charge will be applied. Seals for shaft diameters from 25mm to 2200mm (1 inch to 87 inch) are produced by conventional moulding methods. Sizes above this, and up to unlimited diameter, are manufactured using our highly developed mould-joining technique.

Walkersele® D5 — compact design

A radial lip seal design for very small sections.

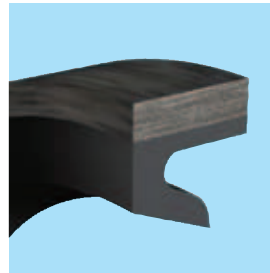
**Special features**

- Very compact design, often used in endless form.
- Feathered lip needs no lip spring for efficient operation.
- This design of seal can be used where space limitations prevent the installation of a lip spring.
- Can be supplied with an external lip for applications where sealing on the inner periphery is impractical.

Walkersele® D5 availability

Existing tools — we hold a number of tools for this design in both lip modes. Please contact us to check mould availability. Where we have a suitable tool, your seal will be supplied on short delivery time without tooling charges.

Walkersele® D4 — slow rotary duties

An early design of Walkersele® that proves very efficient on slow rotary duties with highly abrasive media.

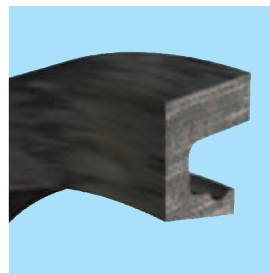
**Special features**

- Moulded entirely in elastomer-proofed fabric for abrasion resistance.
- Suitable only for slow rotary duties with minimal shaft eccentricity. Pulverising mills are a typical application.

Walkersele® D4 availability

This seal has been largely superseded by Walkersele® TBMS. However, we still hold mould tools to satisfy the requirements of existing users and applications. Please contact us to check mould availability. Where we have a suitable tool, your seal will be supplied on short delivery time without tooling charges.

Walkersele® designs

Walkersele® TBMS — tunnel boring machine seal

This design is proven on many major projects, including the Channel Tunnel (7.8m/25.6ft diameter) and the Airport Link Railway, Sydney (11m/36ft diameter).

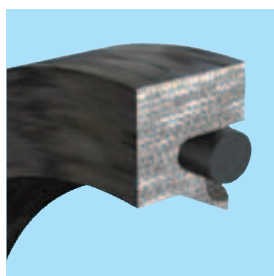

Special features

- Exceedingly robust design of radial lip seal to work for the life of a tunnelling project.
- Moulded entirely in tough, abrasion-resistant, elastomer-proofed fabric.
- Banks of seals are installed to protect the bearings of a TBM's cutting head from water, slurries, abrasive materials, etc.
- Will operate at a constant pressure differential of 300kPa/3bar (43.5psi), with excursions to 400kPa/4bar (58psi). Maximum static pressure differential is 1MPa/10bar (145psi). Note that sealing systems can be designed to step-down higher operating pressures.
- Maximum shaft speed is 2m/s (394fpm).

Walkersele® TBMS availability

We hold a number of standard section continuous-mould tools for the production of large diameter TBMS endless seals.

As tunnel boring machines are usually custom-built for each tunnelling project, please contact our Technical Support Team at concept design stage to discuss sealing requirements in detail.

Walkersele® success

Tunnel boring in Australia

Walkersele® TBMS tunnel boring machine seals protected the cutting face bearings from sand and rock spoil on the 11m diameter machine that cut 6km of the fast-track Airport Link railway line beneath Sydney, Australia.

James Walker supplied the seals to the TBM's German manufacturer, Herrenknecht GmbH.



Walkersele® success

Side thrusters & stabilisers

Cunard Line's 90,000 tonne cruise ship MS Queen Victoria, has Walkerseles fitted as OEM equipment to protect its stabilisers and side thrusters.



Photo by courtesy of Fincantieri SpA

Built at Fincantieri's shipyard in Venice-Marghera, and cruising since December 2007, it is Cunard's second largest ever ship after the Queen Mary 2 — and the first from an Italian yard.

Customised design & testing

Custom design

The creation and production of customer-specific seals is a speciality of James Walker. We constantly design, develop, prototype and prove all types of fluid sealing products in partnership with major equipment manufacturers and end users.

We cover the subject here in general terms only, because most of our work at this level involves non-disclosure agreements.

Our custom design operations are usually led by the James Walker Technology Centre in the UK. This facility combines our Materials Technology, Applications Engineering, and Field Engineering teams.

Staffed with highly experienced product engineers, application engineers, materials technologists and industrial chemists, this group has the proven ability and vast technical resources needed to analyse customers' fluid sealing requirements and to create *best value* working solutions.



In-house design of a new Walkersele®

The main benefits offered by James Walker include:

- On-site analysis of customers' sealing requirements.
- Innovative design capabilities.
- Extremely large range of high-performance elastomers and other materials to choose from, backed with the capability to develop and/or modify materials for specific operational parameters.
- In-house computer modelling, plus banks of dynamic test rigs to simulate operating conditions accurately, to perfect the seal design.
- Prototype manufacturing facilities, including CAD/CAM design and machining of customised mould tools for seal production.
- Fullest knowledge of elastomer and engineering manufacturing technologies.
- A lean manufacturing regime that accommodates non-standard products.

Our custom-design skills are backed by many years' experience of working with engineers across all sectors of industry, and a fundamental understanding of all types of equipment that need high integrity fluid sealing systems.

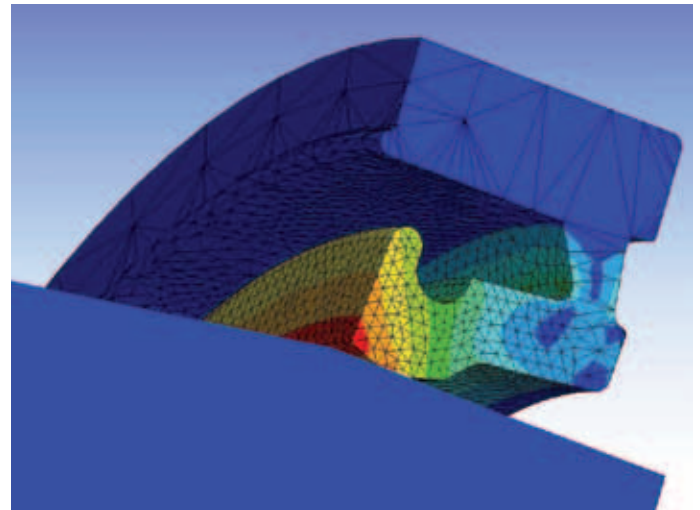

Non-linear FEA model of Walkersele® D8

We use non-linear FEA (finite element analysis) techniques to model mathematically the behaviour of elastomeric seals under simulated operational conditions.

FEA has proved invaluable for the evaluation of design concepts, and for fine-tuning seal-profile/material combinations, prior to the manufacture and physical testing of prototypes. It is also helpful in understanding any modes of failure and poor performance characteristics that a customer may be experiencing with existing sealing systems.



CAD/CAM machining of customised mould tools for Walkersele® production

Customised design & testing

After fine-tuning the design using FEA techniques, the customised seal then moves to prototype production stage followed by physical testing.



Walkersele® production

We have suites of state-of-the-art static and dynamic test rigs that can simulate the operational parameters of virtually every type and complexity of fluid sealing system that we create.

These are used extensively during the development of new products, and also to ensure that optimum performance is maintained for production items. Our testing facilities include:

- Hydraulic seal testing to 42MPa at linear velocities to 0.5m/s.
- Gasket testing to 20MPa with helium.
- Climatic chamber for static testing of seals to 160MPa at temperatures from -70°C to +180°C.
- RGD (rapid gas decompression) testing to 60MPa and 200°C with multiple heat/pressurisation/soak/rapid decompression cycles.



Rotary seal test rigs with data capture

For Walkersele rotary seal testing we use:

- Five dynamic test rigs with 24/7 data capture.
- These have changeable shafts/sleeves of metal or ceramic, covering diameters of 70mm, 160mm, 330mm and 405mm.
- Fluid pressures up to 2.5MPa, with test media that include mineral oils, synthetic oils, water, emulsions...
- Shaft velocities up to 100m/s.
- With direct torque measurement.

With this suite of rotary rigs we can undertake long-term tests on Walkerseles under closely simulated operating conditions. The 24/7 data capture facility enables exacting reports to be produced describing seal performance throughout the full duration of the tests.

Only when James Walker Technology Centre and our customer are fully satisfied with the test rig results will the new custom-designed seal be subjected to field trials on a working plant.



Full test reports are prepared for each customer

Successes on high-profile development projects for our custom designed seals produce very positive feedback. The resulting improvements in seal performance — in terms of sealing integrity, operational life, and the ability to work under extreme conditions — are greatly appreciated by our customers on a worldwide basis.

Typical applications

Walkersele® success

Hydropower turbine

Turbine shaft seals on an EDF hydroelectric scheme at Villeneuve, France, have been converted to Walkersele® using James Walker's patented OSJ® On-Site Joining technique.

Three Walkersele® D7 seals running on a tungsten carbide coated shaft sleeve were fitted in less than three hours.



The original sealing system on the 13MW bulb type turbine proved difficult to keep in good condition in the highly abrasive and corrosive river flow. The Walkerseles last significantly longer, seal more efficiently and are far easier to maintain.

Walkersele® success

Wind turbines

Wind power technology company NEG Micon of Denmark uses 1800mm diameter Walkerseles to protect the slew ring mechanism that keeps the head of its 900kW turbines facing into wind.

A special Walkersele® was custom designed and moulded with an extra dust lip for this application.



Walkersele® success

Propulsion shafts

All M-Class frigates of the Dutch Royal Navy now have Walkerseles installed on their propulsion shafts, following a technical review of the support bearing seals.



The arrangement is based on two Walkersele® lip seals with James Walker's OSJ® (On-Site Joining) technique, plus an automatic lubricant dispenser and new bearing cover. It replaces a labyrinth system that scored the propulsion shaft.

Walkersele® success

Tidal power

The world's first commercially-viable tidal turbine operates in Northern Ireland — with rotor blade bearings protected by Walkersele® radial lip seals.

The prototype SeaGen turbine was installed in Strangford Lough in May 2008 and supplies power to Northern Ireland Electricity.

Each of the turbine's dual 16m diameter rotors has two Walkerseles fitted back-to-back to prevent sea water entering the main bearings and lubricant escaping.



Photo by courtesy of Dr I J Stevenson.

Walkersele® OSJ-2 for On-Site Joining



Walkersele® OSJ is our highly successful technique for the On-Site Joining of split-type Walkerseles. Its many benefits include:

- **High performance** — installed units provide the sealing performance of high-integrity endless Walkerseles.
- **Worldwide proven** — on marine propulsion systems, gearboxes, power stations, sugar refineries, etc.
- **Cost effective maintenance** — the performance and integrity of an endless-type seal is achieved:
 - ▶ without major plant strip-down
 - ▶ without expensive on-site vulcanising.

Walkersele® OSJ — background to success

Innumerable improvements in Walkersele® materials and design have been introduced over the past 60 years.

One of these was the split-type seal that proved invaluable where gland and shaft assemblies had to be dismantled to fit a moulded endless seal. This development drastically cut the costs of plant downtime and maintenance man-hours.

However, normal split seals are not penalty-free, as sealing performance can be affected when shaft dynamics are severe, or when oil levels reach the seal split. Abutting the ends is still a viable option if a small degree of leakage is acceptable.

On-site vulcanising was, for many years, the only answer to split seal assemblies where leakage was unacceptable. But this process could prove expensive, as it needed a high degree of skill and elaborate jigs. So, we developed Walkersele OSJ.

Since the introduction of Walkersele OSJ in 1991, rotary lip seal replacement has come full circle, to form a full circle again. After a few hours' hands-on training, a maintenance fitter is able to produce a securely bonded joint that provides Walkersele with the integrity of a fully moulded endless seal. Fitting procedure is straightforward, as shown alongside.

Improved design

In consultation with long-term OSJ® customers, we have been constantly improving the installation kit to make it easier and more efficient to use under arduous maintenance conditions.

The latest improvements include:

- New 'twin-peg' location of joined ends for easier handling, more accurate location and stronger hold.
- Redesigned jig to provide a more positive location of the seal joint.
- Improved temperature indicator.

Fitting procedure



Stage 1: Apply epoxy adhesive to joining faces of Walkersele® OSJ-2.



Stage 2: Align join in moulded jig.

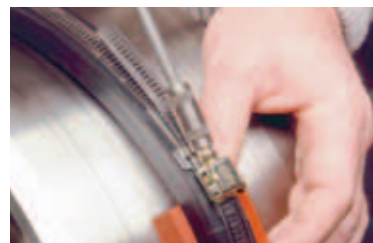

Stage 3: Clamp into position with steel band.



Stage 4: Cure epoxy adhesive with hot air gun.

Walkersele® OSJ-2

OSJ-2 On-Site Joining kit

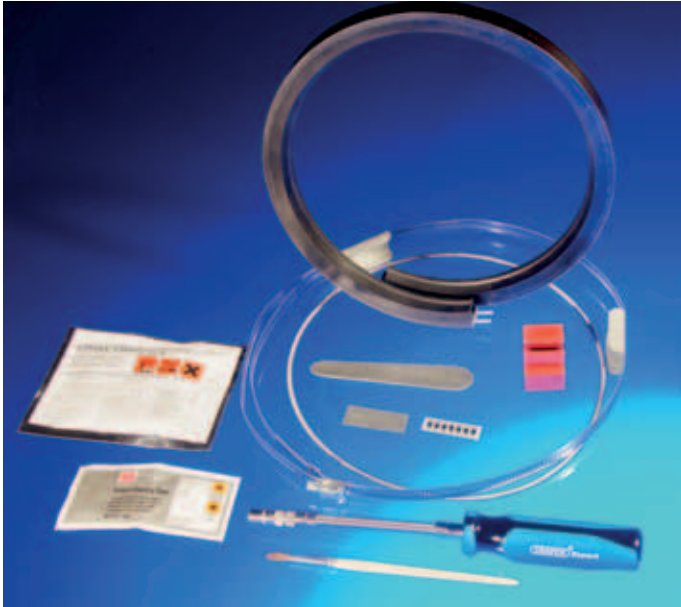
**Kit components**

- Walkersele® — specially adapted at join interface for OSJ® installation.
- Steel clamping band.
- Nut driver to adjust clamping band.
- Joining jig — precision moulded in synthetic elastomer.
- Two-part epoxy adhesive in sachet (adhesive cures to semi-rigid state).
- Adhesive applicator brush.
- Degreasing cloth.
- Abrasive stick.
- Emery paper with self-adhesive backing.
- Temperature indicator with self-adhesive backing (Note: hot air gun is needed to effect adhesive cure).
- Step-by-step instructions.

Training

Successful application of the Walkersele® OSJ technique relies on careful adherence to all stages of the joining process — as laid down in the full instructions supplied with each kit.

We recommend that first-time users attend one of our hands-on training sessions. These can be carried out at your premises or one of our sites.

For details, please contact our Technical Support Team or your local James Walker distributor.

Seal availability**Profiles**

Walkersele OSJ-2 is supplied in all Walkersele designs that incorporate seal backs moulded in rubberised fabric, including:



D1



D1/DL



D5

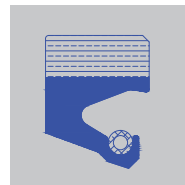

D6

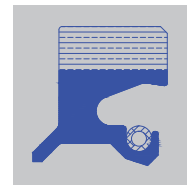

D6/DL



D7



D8

In addition, some TBMS (tunnel boring machine seal) profiles may be suitable for On-Site Joining.

Materials

Walkersele OSJ-2 is supplied in the following elastomers: nitrile (NBR), fluorocarbon (FKM) and hydrogenated nitrile (HNBR), all where the Walkersele material has a rubberised fabric back.

Temperature limits

These are dependent on the seal material. But please note that the bonding technique imposes an upper limit of 150°C (302°F) on the seal.

Sizes

Walkersele OSJ-2 is supplied with twin-peg location for shaft sizes from 60mm to 1500mm OD. We also have On-Site Joining techniques for seals outside this range (eg, offshore wind turbines), and for applications where space is limited — please contact our Technical Support Team for advice.

Performance envelope

If you need further guidance or performance data concerning a specific application, please discuss exact details of media compatibility, pressure, temperature and surface speeds with our Technical Support Team.

Special arrangements for worn shafts

We offer a package of solutions to the problem of shaft wear created beneath the lip position when standard radial lip seals have run under arduous conditions for long periods.

Walkersele® Cartridges

- One or more Walkerseles housed in a custom-designed cartridge allows the seal lip to be located away from areas of shaft wear.
- A split-type cartridge that simply bolts onto the existing equipment face will extend the life of the equipment without the need for major strip-down, shaft reconditioning or replacement.
- Walkersele® cartridges are also custom designed to overcome other problems, including bearing protection for pumps handling highly abrasive media, eccentric shaft action, and long-term sealing with minimised downtime for seal refurbishment.

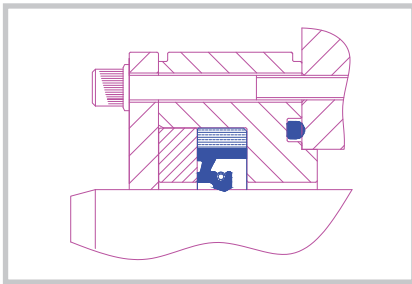

Single seal & spacer
Spacer ring enables the Walkersele lip to be repositioned to avoid shaft wear or damage. This cartridge arrangement shows common bolting for seal and cartridge. Separate bolting is available.

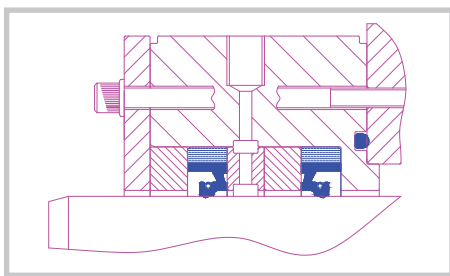

Double seal arrangements
These use two Walkerseles in a cartridge, along with various spacers and/or different widths of lantern ring. By varying the sizes

and positions of these components, the sealing elements are accurately positioned to run on specific areas of the shaft.

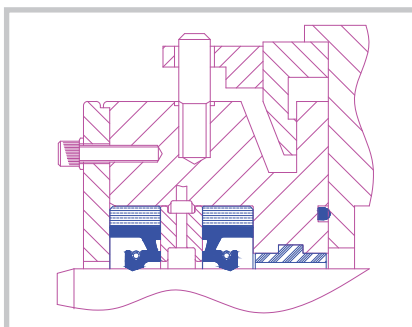

Floating cartridge
This arrangement allows the sealing elements to follow the eccentric movement of worn or misaligned shafts. It is usually applied to large diameter shafts that rotate slowly.

Walkersele® Cartridge availability

Supplied as complete customised package following an on-site assessment of your application. Installation and refurbishment services are also available. Please contact our Technical Support Team.

Spacer rings

These allow a Walkersele®, or combination of seals, to be relocated within a housing so that the lip/s bear on a different area of shaft surface.

When fitted in new equipment, a spacer ring allows sealing lip positions to be readily altered when shaft wear has occurred after a long period of operation. When retrofitting to an existing application, it may be necessary to modify the housing and retaining plate to accommodate the spacer ring/s.

With two (or more) Walkersele D7 seals in a housing, spacer rings must be installed between the seals to support the heel of the seal. This applies equally to seals in series — facing in or facing out — and in back-to-back formation.

Spacer ring availability

Rings are supplied to order to suit specific Walkersele/housing configurations. They are available in various materials, with nylon or stainless steel proving most popular. Please contact our Technical Support Team for recommendations.

Walkersele® Shaft Sleeves

Our sleeves will protect your shaft from wear and present the optimum running surface for Walkersele® radial lip seals. We can provide them in either endless or split form.



The sleeves are precision manufactured in corrosion-resistant steel or non-ferrous alloys, to suit the operating conditions, and can be supplied with hard surface layers when required.

Our split-type sleeves feature a taper-wedge location and locking system that ensures perfect alignment of the split halves.



Shaft sleeve availability

Custom-designed and manufactured to suit each specific application. Please contact our Technical Support Team.

Special features

Our list of Walkersele® special features grows constantly as we introduce new developments to improve the efficiency of our products under specific operating conditions. Here are a few examples.

Walkersele® SpringSafe



Our specially developed SpringSafe technique:

- Provides positive spring retention for Walkersele® D6, D7 and D8 radial lip seals.
- Intimately cures the lip-energising spring into the spring groove to keep the spring securely in position during installation and operation.
- Allows spring coils to move freely for efficient lip seal operation.

With SpringSafe, plant operators enjoy peace-of-mind that the lip-energising springs on their endless-type seals are properly located at installation and cannot readily be dislodged to create secondary damage when a shaft or bearing runs beyond recommended operating limits.

SpringSafe is particularly beneficial on sealing duties where unprotected springs are subjected to the corrosive or abrasive media found in metallurgical processing, marine applications, pulp and paper processing, and petrochemical processing.

Walkersele SpringSafe materials

SpringSafe is currently available for Walkerseles that are precision moulded in:

- Nitrile (NBR) elastomer — ie, materials M1 and M6 (page 12).
- Hydrogenated nitriles (HNBR) — including our reformulated HNBR grades (pages 13 - 14).

Walkersele SpringSafe sizes

Shafts of 250mm (9.8 inch) to 600mm (23.6 inch) diameter can be supplied with Walkersele radial lip seals incorporating the SpringSafe method of positive retention – however, the seal section must be 14.4mm (0.57 inch) or greater for efficient operation.

For SpringSafe on smaller diameter shafts and non-standard sizes, please refer to our Technical Support Team. We are constantly developing and proving extensions to our Walkersele family, so we may well be able to meet your request.

Walkersele® SpringCover

Walkersele® lip-energising springs are supplied as standard in stainless steel, with other materials such as Inconel® available to order.

However, when the seals must operate under extremely corrosive conditions — such as highly oxygenated marine environments — it may be necessary to provide additional protection for the spring by means of Walkersele® SpringCover.

With Walkersele SpringCover, we encase the spring in polyolefin then flush and vacuum fill the inside of the spring with corrosion inhibitor. This combination prevents external fluids from attacking the spring and greatly reduces the possibility of corrosion occurring within the coils.

Walkersele® with Dust Lip

Special versions of our D6 and D1 designs have an auxiliary 'dust lip' incorporated to prevent the ingress of liquid or solid contaminants in aggressive industrial environments. Dust lip (DL) versions are often installed when there is insufficient space to fit two standard seals in a housing – but please note that a dust lip will not seal as efficiently as a separate lip seal.

Special features

- Prevents ingress of external contaminants.
- Needs a smaller housing than double seal (back-to-back) arrangements often used for two-way sealing.
- Fabric-backed versions can be supplied as split types, and as Walkersele® OSJ-2 (pages 22 - 23) for On-Site Joining.

DL availability

Existing tools — we hold many tools for D6/DL and D1/DL. Please contact us to check tool availability. Where we have a suitable tool, your seal will be supplied on short delivery time without tooling charges.

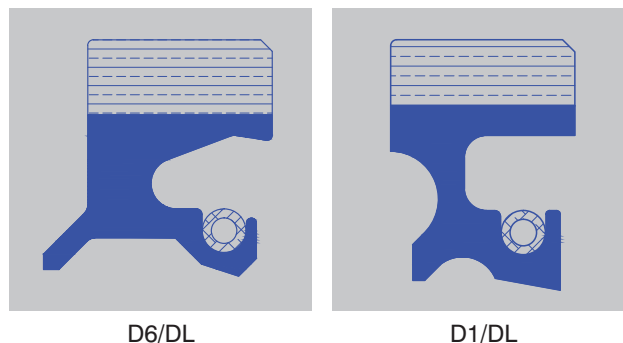

New tools — are swiftly made in-house when the size you need does not exist. In these cases a tooling charge will be applied.

Special features

Walkersele® Shallowback designs

These modified versions of Walkersele® D6 and D7 designs have reduced depth at the back, plus flexible, extended lips.

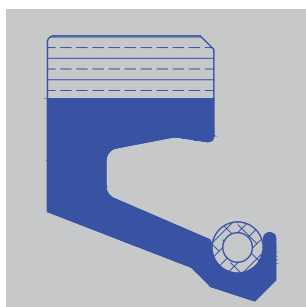

Walkersele® D6 Shallowback

Special features

- Suitable for duties where housing depth limitations preclude the use of standard Walkerseles.
- Can be moulded with the extended lip and standard back for duties where shaft eccentricity is high (*Please consult our Technical Support Team*).
- Shallowback with the extended lip is available for use with angular shaft displacement on spherical bearings/couplings.
- D7 Shallowback is used as a wiper (eg, on automatic gauge control units) where it prevent the ingress of foreign matter.

D6 & D7 Shallowback availability

Existing tools — we hold a limited number of tools for these designs. Please contact us to check mould availability. Where we have a suitable tool, your seal will be supplied on short delivery time without tooling charges.

New tools — are swiftly made in-house when the size you need does not exist. In these cases a tooling charge will be applied.

Walkersele® Long Lip

This modified version of our D6 design incorporates a long lip for sealing applications that involve slow rotary shafts suffering a high degree of eccentricity, or where clearances between the shaft and housing are excessive.

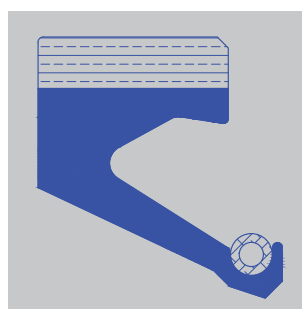

Walkersele® Long Lip availability

Existing tools — we hold a limited number of tools for this design. Please contact us to check availability. Where we have a suitable tool, your seal will be supplied on short delivery time without tooling charges.

New tools — are swiftly made in-house when the size you need does not exist. In these cases a tooling charge will be applied.

Walkersele® with Ports & Grooves

There are many sealing arrangements where two seals are fitted back-to-back in the same housing — eg, rolling mill bearings — and it is possible that one or both will run dry unless lubricant is supplied from an external source.

While it is preferable that lubrication is conducted through a lantern ring located between the Walkerseles, this can also be accomplished by introducing a lubricant flow through the housing to the junction of the two seals. Using Walkerseles that are specially manufactured with an annular groove and radial ports in their backs allows the lubricant to distribute to the lips of both seals.



Walkersele® with Ports and Grooves

Alternative methods are to machine an annular groove in the housing and use Walkerseles that are manufactured with radial

ports, or to install a lantern ring between the seals — albeit this may increase the depth of housing required.

Annular grooves can be provided in Walkerseles of 12.5mm (0.5 inch) section width or greater. Axial ports can be provided on any size of Walkersele.

Special features

Endless-type Walkerseles

All Walkerseles are available in endless form, as a complete ring. However, self-retaining types (eg, M6 and M8 materials) for use in open housings are supplied **only** in endless form as they have a flexible metal band encapsulated in the back.



The main benefit of endless seals is their high integrity sealing capability. But this is often mitigated by the maintenance downtime required for their installation, especially on shaft bearings where the shaft may need to be removed for access.

Hence the development of split-type seals and our **Walkersele OSJ-2 On-Site Joining** technique (pages 22 - 23).

Split-type Walkerseles

Walkerseles with a flexible back of elastomer-proofed fabric (excluding D7 and D8 designs) can be provided as split-types for ease of installation. These include M1, M5, M9, and Elast-O-Lion® material types. Aflas® grades can also be supplied split, but their special benefits with abrasive or chemically aggressive media may be compromised.

A split-type Walkersele is manufactured with a solid elastomer insert where the split is formed. This gives a rubber-to-rubber mating face in the seal's body for close and accurate abutment when the seal is in position. Installation is simple, as the seal is easily opened out around the shaft, the ends mated, and the toroidal lip-energising spring screwed together.

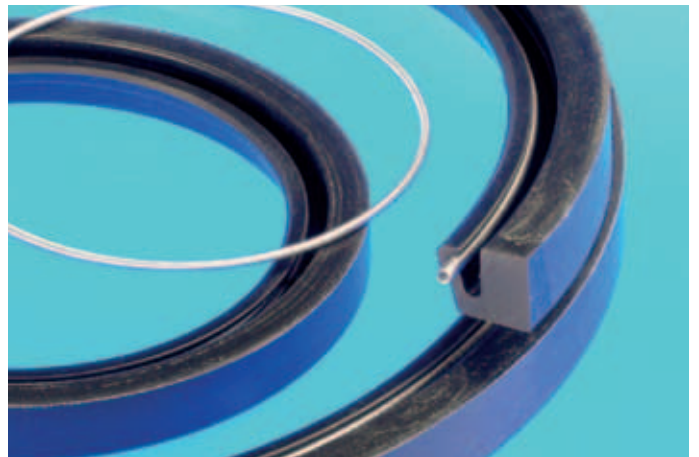

However, the sealing performance of split type seals can be affected when shaft dynamics are severe, or the oil level is above the centre line of the shaft. Thus a small degree of leakage past the abutted ends is always possible.

Our **Walkersele OSJ-2 On-Site Joining** technique overcomes these problems (pages 22 - 23).

Walkersele® M1/D6 standard range

Walkersele® M1/D6

JW Charts 56 and 57, as shown on these two pages, contain our standard ranges of Walkersele® M1/D6 seals for use in housings with retaining plates.

- Chart 56 covers inch size seals.
- Chart 57 covers metric sizes.

All these seals are available ex-stock.

When ordering, please quote the appropriate *JW Part number*, which differentiates between endless-type and split-type seals.

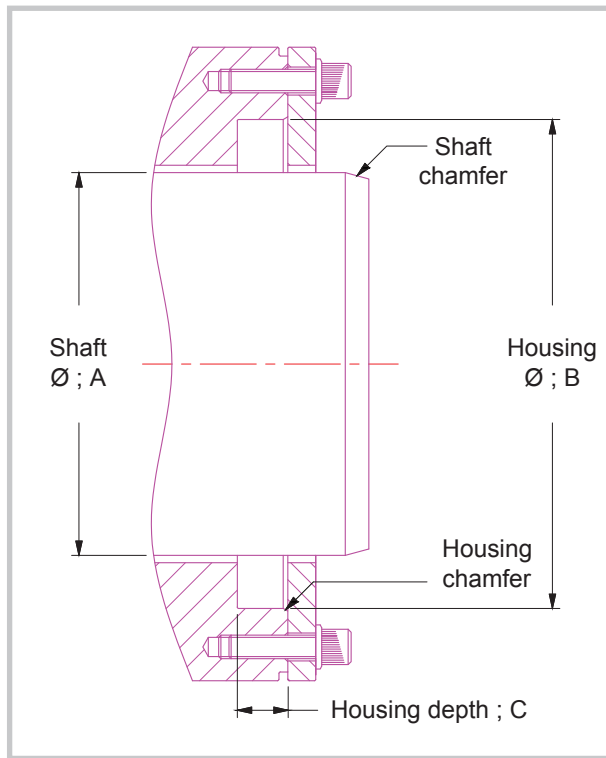

JW Chart 56:
Walkersele® M1/D6 — inch sizes

Shaft Dia A	Housing Dia B	Housing Depth C	JW Chart number	JW Part number ENDLESS	JW Part number SPLIT
1	1 7/8	3/8	56-100	WG000259	WG010254
1 1/8	2	3/8	56-112	WG000283	WG010289
1 1/4	2 1/8	3/8	56-125	WG000313	WG010319
1 3/8	2 1/4	3/8	56-137	WG000348	WG010343
1 1/2	2 1/2	7/16	56-150	WG000380	WG010386
1 5/8	2 5/8	7/16	56-162	WG000410	WG010416
1 3/4	2 3/4	7/16	56-175	WG000445	WG010440
1 7/8	2 7/8	7/16	56-187	WG00047X	WG010475
2	3	7/16	56-200	WG00050X	WG010505
2 1/8	3 1/8	7/16	56-212	WG000534	WG01053X
2 1/4	3 1/4	7/16	56-225	WG000577	WG010572
2 3/8	3 3/8	7/16	56-237	WG000607	WG010602
2 1/2	3 1/2	7/16	56-250	WG000631	WG010637
2 3/4	4	1/2	56-275	WG000690	WG010696
3	4 1/4	1/2	56-300	WG000763	WG010769
3 1/4	4 1/2	1/2	56-325	WG000828	WG010823
3 1/2	4 3/4	1/2	56-350	WG000887	WG010882
3 3/4	5	1/2	56-375	WG00095X	WG010955
4	5 1/4	1/2	56-400	WG001018	WG011013
4 1/4	5 3/4	5/8	56-425	WG001077	WG011072
4 1/2	6	5/8	56-450	WG00114X	WG011145
4 3/4	6 1/4	5/8	56-475	WG001204	WG01120X
5	6 1/2	5/8	56-500	WG001271	WG011277
5 1/4	6 3/4	5/8	56-525	WG001336	WG011331
5 1/2	7	5/8	56-550	WG001395	WG011390
5 3/4	7 1/4	5/8	56-575	WG001468	WG011463
6	7 1/2	5/8	56-600	WG001522	WG011528
6 1/4	7 3/4	5/8	56-625	WG001581	WG011587
6 1/2	8	5/8	56-650	WG001654	WG01165X
6 3/4	8 1/4	5/8	56-675	WG001719	WG011714
7	8 1/2	5/8	56-700	WG001778	WG011773
7 1/2	9	5/8	56-750	WG001905	WG011900
8	9 1/2	5/8	56-800	WG002030	WG012036
8 1/2	10	5/8	56-850	WG002154	WG01215X
9	10 1/2	5/8	56-900	WG002286	WG012281
9 1/2	11	5/8	56-950	WG002413	WG012419
10	11 1/2	5/8	56-1000	WG002545	WG012540
10 1/2	12 1/4	3/4	56-1050	WG002669	WG012664
11	12 3/4	3/4	56-1100	WG002790	WG012796
11 1/2	13 1/4	3/4	56-1150	WG002928	WG012923
12	13 3/4	3/4	56-1200	WG003045	WG013040
13	14 3/4	3/4	56-1300	WG003304	WG01330X
14	15 3/4	3/4	56-1400	WG00355X	WG013555
15	16 3/4	3/4	56-1500	WG003819	WG013814

All dimensions in inches

Walkersele® M1/D6 standard range

JW Chart 57:
Walkersele® M1/D6 — metric sizes

Shaft Dia A	Housing Dia B	Housing Depth C	JW Chart number	JW Part number ENDLESS	JW Part number SPLIT
25	47	10	57-25	WG02025X	WG030255
30	52	10	57-30	WG020306	WG030301
32	54	10	57-32	WG020322	WG030328
35	57	10	57-35	WG020357	WG030352
38	63	11	57-38	WG020381	WG030387
40	65	11	57-40	WG020403	WG030409
42	67	11	57-42	WG02042X	WG030425
43	68	11	57-43	WG020438	WG030433
45	70	11	57-45	WG020454	WG03045X
50	75	11	57-50	WG020500	WG030506
53	78	11	57-53	WG020535	WG030530
55	80	11	57-55	WG020551	WG030557
58	83	11	57-58	WG020586	WG030581
60	85	11	57-60	WG020608	WG030603
65	90	11	57-65	WG020659	WG030654
68	100	12.5	57-68	WG020683	WG030689
70	102	12.5	57-70	WG020705	WG030700
73	105	12.5	57-73	WG02073X	WG030735
75	107	12.5	57-75	WG020756	WG030751
80	112	12.5	57-80	WG020802	WG030808
82	114	12.5	57-82	WG020829	WG030824
85	117	12.5	57-85	WG020853	WG030859
88	120	12.5	57-88	WG020888	WG030883
90	122	12.5	57-90	WG02090X	WG030905
93	125	12.5	57-93	WG020934	WG03093X
95	127	12.5	57-95	WG020950	WG030956
97	129	12.5	57-97	WG020977	WG030972
100	132	12.5	57-100	WG021000	WG031006
105	145	16	57-105	WG021051	WG031057
110	150	16	57-110	WG021108	WG031103
115	155	16	57-115	WG021159	WG031154
120	160	16	57-120	WG021205	WG031200
125	165	16	57-125	WG021256	WG031251
130	170	16	57-130	WG021302	WG031308
135	175	16	57-135	WG021353	WG031359
140	180	16	57-140	WG02140X	WG031405
145	185	16	57-145	WG021450	WG031456
150	190	16	57-150	WG021507	WG031502
155	195	16	57-155	WG021558	WG031553
160	200	16	57-160	WG021604	WG03160X
165	205	16	57-165	WG021655	WG031650
166	206	16	57-166	WG021663	WG031669
170	210	16	57-170	WG021701	WG031707
175	215	16	57-175	WG021752	WG031758
180	220	16	57-180	WG021809	WG031804
185	225	16	57-185	WG02185X	WG031855
190	230	16	57-190	WG021906	WG031901
195	235	16	57-195	WG021957	WG031952
200	240	16	57-200	WG022007	WG032002
205	245	16	57-205	WG022058	WG032053
210	250	16	57-210	WG022104	WG03210X
215	255	16	57-215	WG022155	WG032150
220	260	16	57-220	WG022201	WG032207

JW Chart 57:
Walkersele® M1/D6 — metric sizes (continued)

Shaft Dia A	Housing Dia B	Housing Depth C	JW Chart number	JW Part number ENDLESS	JW Part number SPLIT
225	265	16	57-225	WG022252	WG032258
230	270	16	57-230	WG022309	WG032304
235	275	16	57-235	WG02235X	WG032355
240	280	16	57-240	WG022406	WG032401
245	285	16	57-245	WG022457	WG032452
250	290	16	57-250	WG022503	WG032509
255	299	20	57-255	WG022554	WG03255X
260	304	20	57-260	WG022600	WG032606
265	309	20	57-265	WG022651	WG032657
270	314	20	57-270	WG022708	WG032703
275	319	20	57-275	WG022759	WG032754
280	324	20	57-280	WG022805	WG032800
285	329	20	57-285	WG022856	WG032851
290	334	20	57-290	WG022902	WG032908
295	339	20	57-295	WG022953	WG032959
296	340	20	57-296	WG022961	WG032967
300	344	20	57-300	WG023003	WG033009
305	349	20	57-305	WG023054	WG03305X
310	354	20	57-310	WG023100	WG033106
320	364	20	57-320	WG023208	WG033203
325	369	20	57-325	WG023259	WG033254
330	374	20	57-330	WG023305	WG033300
340	384	20	57-340	WG023402	WG033408
350	394	20	57-350	WG02350X	WG033505
360	404	20	57-360	WG023607	WG033602
370	414	20	57-370	WG023704	WG03370X
380	424	20	57-380	WG023801	WG033807
390	434	20	57-390	WG023909	WG033904
400	444	20	57-400	WG02400X	WG034005
413	463	22	57-413	WG024131	WG034137
420	470	22	57-420	WG024204	WG03420X
430	480	22	57-430	WG024301	WG034307
440	490	22	57-440	WG024409	WG034404
450	500	22	57-450	WG024506	WG034501
455	505	22	57-455	WG024557	WG034552
460	510	22	57-460	WG024603	WG034609
475	525	22	57-475	WG024751	WG034757
480	530	22	57-480	WG024808	WG034803
485	535	22	57-485	WG024859	WG034854
500	550	22	57-500	WG025006	WG035001
530	580	22	57-530	WG025308	WG035303
540	590	22	57-540	WG025405	WG035400
560	610	22	57-560	WG02560X	WG035605
580	630	22	57-580	WG025804	WG03580X
600	650	22	57-600	WG026002	WG036008
650	714	25	57-650	WG026509	WG036504
660	724	25	57-660	WG026606	WG036601
700	764	25	57-700	WG027009	WG037004
750	814	25	57-750	WG027505	WG037500
790	854	25	57-790	WG027904	WG03790X
800	864	25	57-800	WG028005	WG038000
820	884	25	57-820	WG02820X	WG038205
830	894	25	57-830	WG028307	WG038302
970	1034	25	57-970	WG029702	WG039708
1000	1064	25	57-1000	WG029990	WG039996

All dimensions in mm

Walkersele® M6/D6 standard range

Walkersele® M6/D6

JW Charts 104, 105 and 376, as shown on the following three pages, contain our standard ranges of self-retaining Walkersele® M6/D6 seals for use with open housings.

- Chart 104 covers inch size seals.
- Chart 105 covers metric sizes.
- Chart 376 covers seals conforming to the widely used DIN3760 and the equivalent (BS) ISO 6194 standard, as previously covered by BS 1399.

All these seals are available ex-stock.

When ordering, please quote the appropriate *JW Part number*. As these seals are self-retaining they are supplied only as endless types.

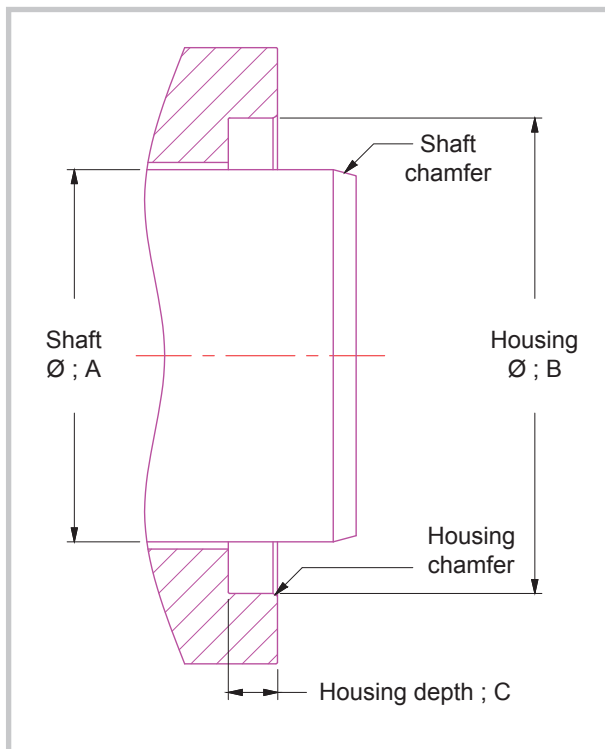

JW Chart 104 Walkersele® M6/D6 — inch sizes

Shaft Dia A	Housing Dia B	Housing Depth C	JW Chart number	JW Part number
2	3	7/16	104-200	WG050507
2 1/8	3 1/8	7/16	104-212	WG05054X
2 1/4	3 1/4	7/16	104-225	WG050574
2 3/8	3 3/8	7/16	104-237	WG050604
2 1/2	3 1/2	7/16	104-250	WG050639
2 3/4	4	1/2	104-275	WG050701
3	4 1/4	1/2	104-300	WG050760
3 1/4	4 1/2	1/2	104-325	WG050833
3 1/2	4 3/4	1/2	104-350	WG050892
3 3/4	5	1/2	104-375	WG050957
4	5 1/4	1/2	104-400	WG051015
4 1/4	5 3/4	5/8	104-425	WG051074
4 1/2	6	5/8	104-450	WG051147
4 3/4	6 1/4	5/8	104-475	WG051201
5	6 1/2	5/8	104-500	WG051279
5 1/4	6 3/4	5/8	104-525	WG051333
5 1/2	7	5/8	104-550	WG051392
5 3/4	7 1/4	5/8	104-575	WG051465
6	7 1/2	5/8	104-600	WG05152X
6 1/4	7 3/4	5/8	104-625	WG051589
6 1/2	8	5/8	104-650	WG051651
6 3/4	8 1/4	5/8	104-675	WG051716
7	8 1/2	5/8	104-700	WG051775
7 1/2	9	5/8	104-750	WG051902
8	9 1/2	5/8	104-800	WG052038
8 1/2	10	5/8	104-850	WG05216X
9	10 1/2	5/8	104-900	WG052283
9 1/2	11	5/8	104-950	WG052410
10	11 1/2	5/8	104-1000	WG052542
10 1/2	12 1/4	3/4	104-1050	WG052666
11	12 3/4	3/4	104-1100	WG052798
11 1/2	13 1/4	3/4	104-1150	WG052925
12	13 3/4	3/4	104-1200	WG053042
13	14 3/4	3/4	104-1300	WG053301
14	15 3/4	3/4	104-1400	WG053557
15	16 3/4	3/4	104-1500	WG053816

All dimensions in inches

Walkersele® M6/D6 standard range

JW Chart 105
Walkersele® M6/D6 — metric sizes

Shaft Dia A	Housing Dia B	Housing Depth C	JW Chart number	JW Part number
50	75	11	105-50	WG060502
55	80	11	105-55	WG060553
60	85	11	105-60	WG06060X
65	90	11	105-65	WG060650
70	102	12.5	105-70	WG060707
75	107	12.5	105-75	WG060758
80	112	12.5	105-80	WG060804
85	117	12.5	105-85	WG060855
90	122	12.5	105-90	WG060901
95	127	12.5	105-95	WG060952
100	132	12.5	105-100	WG061002
105	145	16	105-105	WG061053
110	150	16	105-110	WG06110X
115	155	16	105-115	WG061150
120	160	16	105-120	WG061207
125	165	16	105-125	WG061258
130	170	16	105-130	WG061304
135	175	16	105-135	WG061355
140	180	16	105-140	WG061401
145	185	16	105-145	WG061452
150	190	16	105-150	WG061509
160	200	16	105-160	WG061606
170	210	16	105-170	WG061703
180	220	16	105-180	WG061800
190	230	16	105-190	WG061908
200	240	16	105-200	WG062009
210	250	16	105-210	WG062106
220	260	16	105-220	WG062203
230	270	16	105-230	WG062300
240	280	16	105-240	WG062408
250	290	16	105-250	WG062505
260	304	20	105-260	WG062602
270	314	20	105-270	WG06270X
280	324	20	105-280	WG062807
290	334	20	105-290	WG062904
300	344	20	105-300	WG063005
310	354	20	105-310	WG063102
320	364	20	105-320	WG06320X
330	374	20	105-330	WG063307
340	384	20	105-340	WG063404
350	394	20	105-350	WG063501
360	404	20	105-360	WG063609
370	414	20	105-370	WG063706
380	424	20	105-380	WG063803
390	434	20	105-390	WG063900
400	444	20	105-400	WG064001
420	470	22	105-420	WG064206

JW Chart 105
Walkersele® M6/D6 — metric sizes (continued)

Shaft Dia A	Housing Dia B	Housing Depth C	JW Chart number	JW Part number
440	490	22	105-440	WG064400
460	510	22	105-460	WG064605
480	530	22	105-480	WG06480X
500	550	22	105-500	WG065008

All dimensions in mm

JW Chart 376
Walkersele® M6/D6/M — to DIN 3760/ (BS) ISO 6194-1

	Shaft Dia A	Housing Dia B	Housing Depth C	JW Chart number	JW Part number
*	62	85	10	376-062085	WG040609
*	62	90	10	376-062090	WG040625
*	63	85	10	376-063085	WG040633
*	63	90	10	376-063090	WG040641
	65	85	10	376-065085	WG04065X
	65	90	10	376-065090	WG040668
*	65	100	10	376-065100	WG040676
*	68	90	10	376-068090	WG040684
*	68	100	10	376-068100	WG040692
	70	90	10	376-070090	WG040706
	70	95	10	376-070095	WG040714
*	70	100	10	376-070100	WG040722
*	72	95	10	376-072095	WG040730
*	72	100	10	376-072100	WG040749
	75	95	10	376-075095	WG040765
	75	100	10	376-075100	WG040757
*	78	100	10	376-078100	WG040781
	80	100	10	376-080100	WG040803
	80	110	10	376-080110	WG040811
	85	110	12	376-085110	WG040854
	85	120	12	376-085120	WG040862
	90	110	12	376-090110	WG040889
	90	120	12	376-090120	WG040900
	95	120	12	376-095120	WG040951
	95	125	12	376-095125	WG04096X
	100	120	12	376-100120	WG040986
	100	125	12	376-100125	WG041001
	100	130	12	376-100130	WG041028
	105	130	12	376-105130	WG041052
*	105	140	12	376-105140	WG041060
	110	130	12	376-110130	WG041109
	110	140	12	376-110140	WG041117
	115	140	12	376-115140	WG04115X
*	115	150	12	376-115150	WG041168

All dimensions in mm (continued overleaf)

Walkersele® M6/D6 standard range

JW Chart 376 (continued)

Walkersele® M6/D6/M — to DIN 3760/ (BS) ISO 6194-1

	Shaft Dia A	Housing Dia B	Housing Depth C	JW Chart number	JW Part number
	120	150	12	376-120150	WG041206
*	120	160	12	376-120160	WG041222
	125	150	12	376-125150	WG041249
*	125	160	12	376-125160	WG041257
	130	160	12	376-130160	WG041303
*	130	170	12	376-130170	WG04132X
	135	170	12	376-135170	WG041354
	140	170	15	376-140170	WG041400
	145	175	15	376-145175	WG041451
	150	180	15	376-150180	WG041508
	160	190	15	376-160190	WG041605
	170	200	15	376-170200	WG041702
	180	210	15	376-180210	WG04180X
	190	220	15	376-190220	WG041907
	200	230	15	376-200230	WG042008
	210	240	15	376-210240	WG042105
	220	250	15	376-220250	WG042202
	230	260	15	376-230260	WG04230X
	240	270	15	376-240270	WG042407
	250	280	15	376-250280	WG042504
	260	300	20	376-260300	WG042601
	280	320	20	376-280320	WG042806
	300	340	20	376-300340	WG043004
	320	360	20	376-320360	WG043209
	340	380	20	376-340380	WG043403
	360	400	20	376-360400	WG043608
	380	420	20	376-380420	WG043802
	400	440	20	376-400440	WG044000
	420	460	20	376-420460	WG044205
	440	480	20	376-440480	WG04440X
	460	500	20	376-460500	WG044604
	480	520	20	376-480520	WG044809
	500	540	20	376-500540	WG045007

All dimensions in mm

* These sizes no longer appear in the standards quoted.

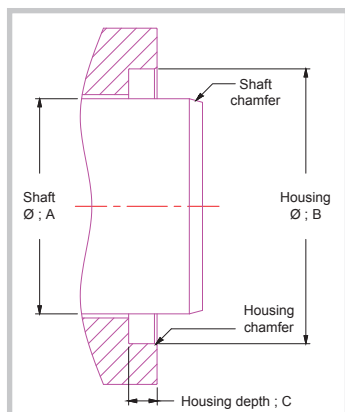

Walkersele® success

Side thrusters repairs

Swift action by James Walker and Blohm + Voss Repair ensured that the Queen Mary 2 cruise liner set sail on time after 11 days of classification work, painting and plant overhaul at Hamburg.



Four 220mm Walkersele® M1/D7 seals were identified, precision moulded in the UK, and delivered to Hamburg in just two days to complete unscheduled work on the ship's starboard bow thrusters.

Housing design & machining requirements

Housings for Walkersele® D6, D7 & D8 designs

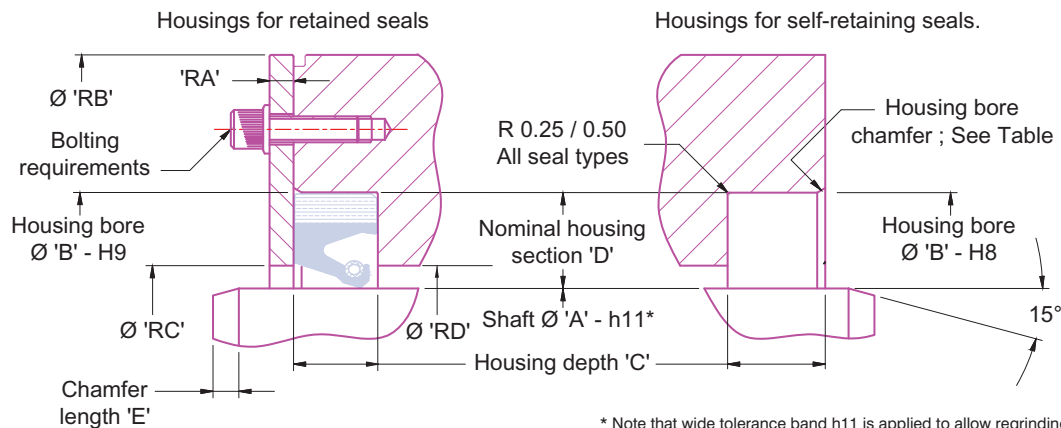

* Note that wide tolerance band h11 is applied to allow regrinding of worn shafts and may not necessarily reflect the original manufacturing tolerances.

Nominal housing dimensions

Recommended housing depths and sections for given shaft sizes

Walkersele® D6 design

Retained seals								Self-retaining seals							
Shaft Ø 'A'				Nominal housing sizes				Shaft Ø 'A'				Nominal housing sizes			
mm		inch		Depth 'C'		Section 'D'		mm		inch		Depth 'C'		Section 'D'	
>	≤	>	≤	mm	inch	mm	inch	>	≤	>	≤	mm	inch	mm	inch
-	35	-	1 3/8	10	3/8	11	7/16	-	65	-	2 1/2	10	3/8	10	3/8
35	65	1 3/8	2 1/2	11	7/16	12.5	1/2	65	100	2 1/2	4	12.5	1/2	12.5	1/2
65	100	2 1/2	4	12.5	1/2	16	5/8	100	250	4	10	15	5/8	15	5/8
100	250	4	10	16	5/8	20	3/4	250	400	10	16	20	3/4	20	3/4
250	400	10	16	20	3/4	22	7/8	400	600	16	24	22	7/8	22	7/8
400	600	16	24	22	7/8	25	1	600	900	24	35 1/2	25	1	25	1
600	-	24	-	25	1	32	1 1/4								

Walkersele® D7 & D8 designs

Retained seals								Self-retaining seals							
Shaft Ø 'A'				Nominal housing sizes				Shaft Ø 'A'				Nominal housing sizes			
mm		inch		Depth 'C'		Section 'D'		mm		inch		Depth 'C'		Section 'D'	
>	≤	>	≤	mm	inch	mm	inch	>	≤	>	≤	mm	inch	mm	inch
30	100	1.18	3.94	15	0.591	17.5	0.591	30	250	1.18	9.84	15	0.591	15	0.591
100	250	3.94	9.84	16	0.630	20	0.689	250	330	9.84	12.99	16	0.630	17.5	0.689
250	400	9.84	15.75	20	0.787	22	0.787	330	450	12.99	17.72	20	0.787	20	0.787
400	600	15.75	23.62	22	0.866	25	0.984	450	600	17.72	23.62	22	0.866	25	0.984
600	-	23.62	-	25	0.984	32	1.181	600	-	23.62	-	25	0.984	30	1.181

Housing depth 'C' tolerances

Single seal	Double seals	
	mm	
± 0.1	+ 0.2	- 0
	inch	
± 0.004	+ 0.008	- 0

Housing design & machining requirements

Shaft & housing diameter tolerances — based on BS EN ISO 286-1 & 286-2

Nominal Ø (mm)		All seals, shaft Ø tolerance; h11* (mm)		Retained seals, housing Ø tolerance; H9 (mm)		Self-retaining seals, housing Ø tolerance; H8 (mm)	
>	≤	Low	High	Low	High	Low	High
18	30	- 0	-0.13	- 0	+ 0.052	- 0	+ 0.033
30	50	- 0	-0.16	- 0	+ 0.062	- 0	+ 0.039
50	80	- 0	-0.19	- 0	+ 0.074	- 0	+ 0.046
80	120	- 0	-0.22	- 0	+ 0.087	- 0	+ 0.054
120	180	- 0	-0.25	- 0	+ 0.100	- 0	+ 0.063
180	250	- 0	-0.29	- 0	+ 0.115	- 0	+ 0.072
250	315	- 0	-0.32	- 0	+ 0.130	- 0	+ 0.081
315	400	- 0	-0.36	- 0	+ 0.140	- 0	+ 0.089
400	500	- 0	-0.40	- 0	+ 0.155	- 0	+ 0.097
500	630	- 0	-0.44	- 0	+ 0.175	- 0	+ 0.110
630	800	- 0	-0.50	- 0	+ 0.200	- 0	+ 0.125
800	1000	- 0	-0.56	- 0	+ 0.230	- 0	+ 0.140

* Note that wide tolerance band h11 is applied to allow regrinding of worn shafts and may not necessarily reflect the original manufacturing tolerances.

Chamfer details

Shaft chamfer			Housing bore chamfer	
Shaft Ø 'A'		Shaft chamfer length 'E' Min	mm	
>	≤		Where the nominal housing depth is equal to seal depth up to and including a seal depth of 10.00mm, the chamfer should not exceed 1.00mm x 30°. For all seals above 10.00mm deep, the chamfer should not exceed 2.00mm x 30°.	
mm			inch	
3	50	8	Where the nominal housing depth is equal to seal depth up to and including a seal depth of 3/8 inch, the chamfer should not exceed 0.04 inch x 30°. For all seals above 3/8 inch deep, the chamfer should not exceed 0.08 inch x 30°.	
50	250	10		
250	900	15		
900	-	20		
inch				
0.12	1.97	5/16		
1.97	9.85	3/8		
9.85	31.50	9/16		
31.50	-	3/4		

Retaining plate dimensions & bolting details

Shaft Ø 'A' (mm)		Plate thickness - 'RA' Min (mm)		Outside Ø - 'RB' Min (mm)	Inside Ø - 'RC' Max (mm)		Inside Ø - 'RD' Max (mm)	Bolting requirements		
>	≤	Single seal	Double seal		D6 design	D7 & D8 designs		D6 design	Ø (mm)	Number of bolts
-	35	3.0	4.5	Ø B + 28	Ø A + 0.75C	Ø A + 3	(Ø A + Ø B)/2	M5	4	Ø B + 13
35	65	4.0	6.0	Ø B + 30	Ø A + 0.75C	Ø A + 3	(Ø A + Ø B)/2	M5	6	Ø B + 13
65	100	5.0	7.5	Ø B + 43	Ø A + 0.75C	Ø A + 3	(Ø A + Ø B)/2	M8	6	Ø B + 20
100	250	7.0	10.5	Ø B + 45	Ø A + 0.75C	Ø A + 4	(Ø A + Ø B)/2	M8	8	Ø B + 20
250	400	8.0	12.0	Ø B + 56	Ø A + 0.75C	Ø A + 4	(Ø A + Ø B)/2	M10	8	Ø B + 24
400	600	10.0	15.0	Ø B + 65	Ø A + 0.75C	Ø A + 4	(Ø A + Ø B)/2	M12	12	Ø B + 30
600	900	12.5	18.8	Ø B + 76	Ø A + 0.75C	Ø A + 5	(Ø A + Ø B)/2	M14	16	Ø B + 34
900	1200	15.0	22.5	Ø B + 76	Ø A + 0.75C	Ø A + 5	(Ø A + Ø B)/2	M14	20	Ø B + 34

Note 1: Retaining plate thicknesses and bolting recommendations are based on steel and stainless steel alloys. These recommendations may also be applied to aluminium alloys for endless retaining plates. Please consult us where aluminium alloy retaining plates in split form are intended to be used.

Note 2: Walkersele® D7 and D8 designs need a retaining plate covering the full base width of the seal to support the heel under fluid pressure conditions, especially when an otherwise 'self-retaining' seal is fitted with its heel facing outwards.

Walkersele® fitting techniques

General preparation for all installations

Important: It is inadvisable to re-install a Walkersele® once it has been removed from its housing. To ensure long-term efficient operation, we suggest you fit a new Walkersele.

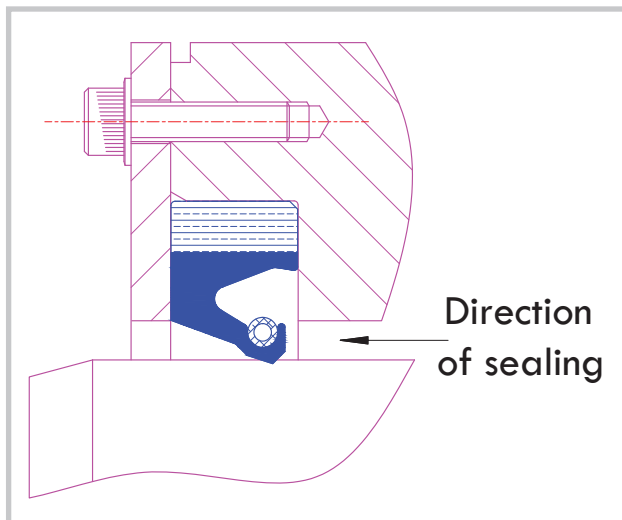

1) The groove formed between the lip seal and the back should normally face the direction to be sealed.

2) With an endless seal, a lead-in should be provided at the ends of shafts, roll necks, abutment rings, etc, over which the seal has to pass, to avoid damaging the seal lips (see *Chamfer details*, page 34).

A: Fabric back endless seals

(eg, endless types M1, M5, M9, M11, M12, M13, M22, Millglide K, Supaglide K, Ultraglide K, or Aflas®)



A1) Apply a smear of oil or grease to the seal lip, spring housing recess, and shaft, immediately before fitting the seal. For this use the bearing lubricant or other lubricant compatible with the media being sealed.



A2) Ensure spring is fitted correctly in recess behind the seal lip.

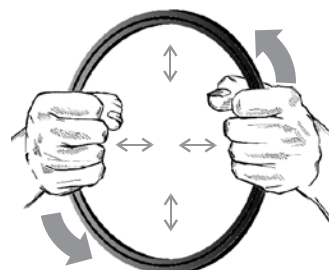

A3) Flex the seal in hands to ensure an even distribution of spring tension.



3) Thoroughly clean the housing and adjacent shaft. Wipe the seal with a clean cloth to remove any dust that has collected in storage.

Important: When seal is in housing, the spring and lip should face the fluid to be sealed.



A4) <500mm OD — insert seal evenly into housing to one-third of seal depth.

>500mm OD — insert seal into housing to one-third of seal depth at 12, 6, 9 & 3 o'clock positions respectively. Then fit at intermediate positions.



4) Check that seal is correct size for shaft and housing, and shaft and housing are burr-free.

Walkersele® fitting techniques

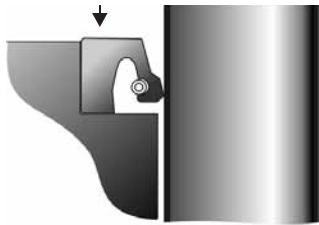

A5) Push seal firmly and evenly until it is seated securely at bottom of the housing.

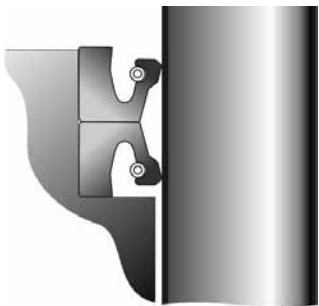

A6) Fit further seal, if required, following steps A1 to A5.

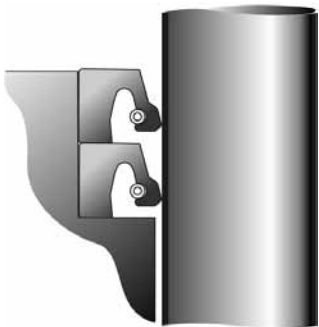

A7) Fit retaining plate and tighten evenly until metal-to-metal contact is achieved.

Note: A lip support plate, where needed, is fitted prior to the retaining plate. Push the lip support plate firmly and evenly into position until seated securely at the base of the Walkersele®. Ensure the installed lip support plate does not contact the shaft.

B: Fabric back split seals

(eg, split types M1, M5, M12, M22, Millglide K, Supaglide K, or Ultraglide K)



B1) Take the seal spring and unscrew at join. It has a left-hand thread.

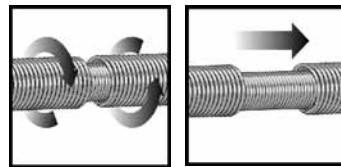

B2) Place spring around shaft. Twist spring several times as if unscrewing, then place ends together and rejoin spring by screwing ends together in opposite direction.

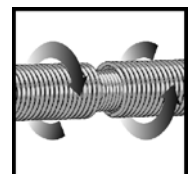
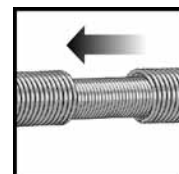
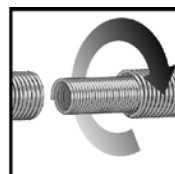
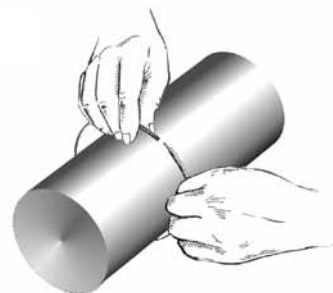

B3) Bend outwards the ends of the seal to counteract any tendency to curl inwards.



Walkersele® fitting techniques



B4) Apply a smear of oil or grease to the seal lip, spring housing groove, and shaft, immediately before fitting the seal. For this use the bearing lubricant or other lubricant compatible with the media being sealed.

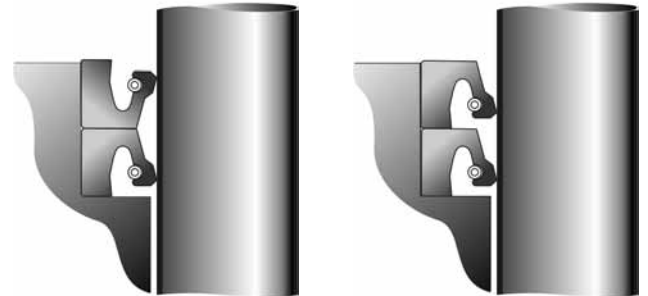

B8) Fit further seal, if required, following steps B1 to B7.

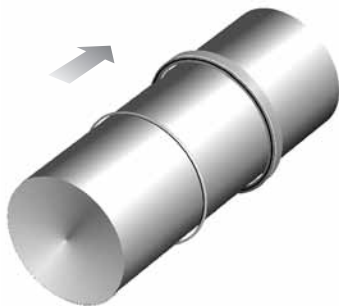

B5) Pass seal around shaft, with lip and spring recess facing the fluid to be sealed. Carefully fit spring into the recess behind the lip.

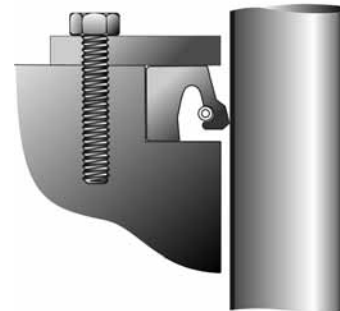

B9) Fit retaining plate and tighten evenly until metal-to-metal contact is achieved.

Important: When seal is in housing, the spring and lip should face the fluid to be sealed.



B6) Insert seal evenly into housing with split section first. On horizontal shafts put split at top.

<500mm OD — insert seal evenly into housing to one-third of seal depth.

>500mm OD — insert seal into housing to one-third of seal depth at 12, 6, 9 & 3 o'clock positions respectively. Then fit at intermediate positions.

C: Metal band — Self-retaining seal (eg, endless types M6 or M8 with 'M' or 'S' backs; Millglide M, Supaglide M, or Ultraglide M)



C1) Apply a smear of oil or grease to the seal lip, spring housing groove, and shaft, immediately before fitting the seal. For this use the bearing lubricant or other lubricant compatible with the media being sealed.

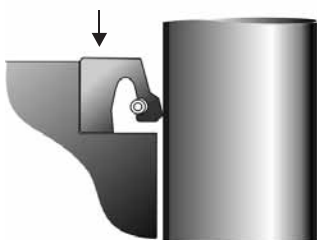

B7) Push seal firmly and evenly until it is seated securely at bottom of the housing.

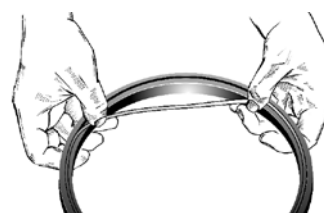

C2) Ensure spring is fitted correctly in recess behind the seal lip.

Walkersele® fitting techniques

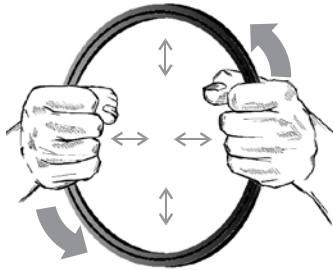

C3) Flex the seal in hands to ensure an even distribution of spring tension.

Important: When seal is in housing, the spring and lip should face the fluid to be sealed. If join in metal band is visible, insert this area first.



C4) <70mm OD — insert seal evenly into housing.

70mm to 450mm OD — leave one-fifth of seal circumference out of housing, then ease in using downwards and inwards pressure.

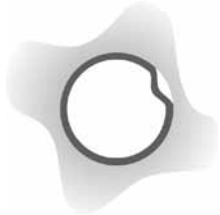

>450mm OD — loop the seal into the housing. Do not dislodge the spring.

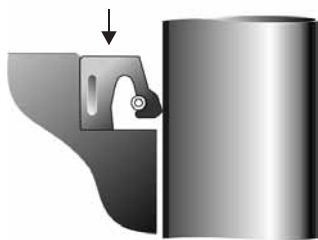

C5) Push seal firmly and evenly until it is seated securely at bottom of the housing.



C6) Fit further seal, if required, following steps C1 to C5.

D: Fitting self-retaining lip seals (eg, M6 & M8) in blind housing



D1) Apply a smear of oil or grease to the seal lip. For this use the bearing lubricant or other lubricant compatible with the media being sealed.

Then liberally lubricate the seal OD with soapy water. This ensures that the outside diameter interference becomes evenly distributed, and eases the fitting process.

Important: When seal is in housing, the spring and lip should face the fluid to be sealed. If join in metal band is visible, insert this area first.

D2) Enter the seal into the blind housing for as much as the circumference as possible. This will leave about one-quarter of the circumference to be manipulated into position.

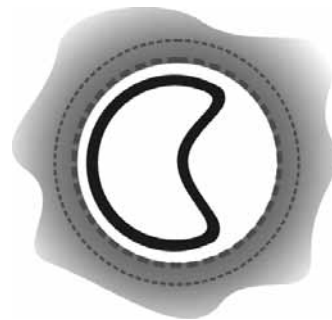

D3) Loop the last portion of the seal circumference into a crescent shape. Then using only hands, urge it into the housing bore until it forms a circle. Do not dislodge the spring.

D4) Ensure the seal is fully seated in the base of the housing around its entire circumference. If necessary, press or tap the seal evenly into its final axial position — use only a flat fitting tool with rounded edges applied to the outer diameter of the seal.

D5) Fit a further seal, if required, following steps D1 to D4. Ensure that second seal is firmly seated against the first seal.

D6) Replace seal housing and bolt up evenly until it is hard against the bearing housing face.

Operational considerations

Multi-seal configurations

In the vast majority of Walkersele® applications a single seal will provide the level of protection required.

On occasions, however, two or more seals in various configurations are necessary to ensure long-term protection under particularly arduous operating conditions. The following are a few examples:

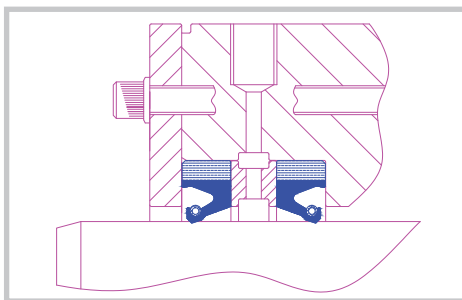

Back-to-back configuration for two-way sealing. Used to prevent loss of bearing lubricant and also prevent ingress of external contaminants.

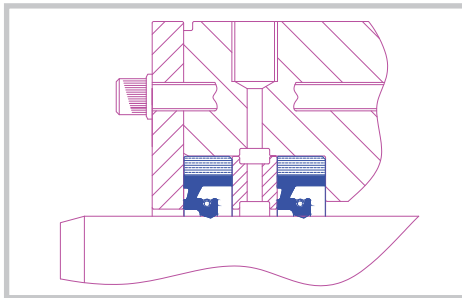

Inward-facing series configuration for extra protection. Typically used to prevent bearing lubricant reaching a product where contamination is not permitted.

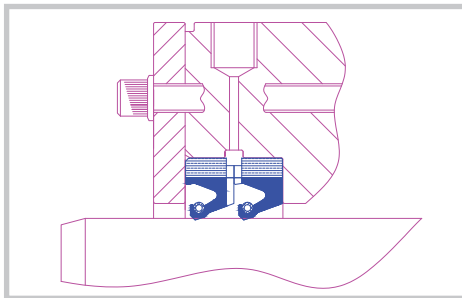

Outward-facing series configuration for extra protection. Typically used to prevent aggressive media reaching the bearings. Where the seal retaining plate is on the sealed fluid side – eg, marine stabilisers – we recommend the application of a suitable flange sealant between the faces of the retaining plate and housing.

Please note that Walkersele D7 and D8 seals need heel support, even in the back-to-back configuration.

We recommend you discuss multi-seal configurations with our Technical Support Team to determine the optimum sealing system for your application.

Excessive pressure behind a Walkersele

A Walkersele works efficiently when the lip and spring face the direction to be sealed. But any excessive fluid pressure applied behind the seal — eg, when injecting lubricant through a lantern ring — can cause the pressurised fluid to pass beneath the seal lip towards the media to be sealed.

Seal lubrication

The sealing lip of a Walkersele® will usually have adequate lubrication for long-life operation when:

- A single seal is fitted to retain lubricant within a bearing assembly.
- Two seals are housed together, with bearing lubricant acting on one and, typically, rolling fluid or coolant acting on the other.

However, when more than two seals — and sometimes only two, on arduous duties — are housed together, the danger exists that one or more will run dry unless lubricated from an exterior source. To accomplish this:

- Ensure that the housing arrangement allows lubricant to pass through freely to the position where the seals meet.
- Install standard Walkerseles with an inter-seal lantern ring/s between them that is ported to allow lubricant access to the inter-seal shaft area and the seal lips (see diagram below). We can supply suitable lantern rings in metal or plastic; please contact our Technical Support Team.

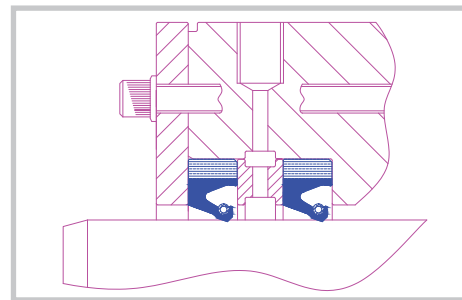

Standard seals with lantern ring (preferred option for inter-seal lubrication).

Where there is insufficient axial space to incorporate a lantern ring:

- Machine an annular groove in the back of the housing to connect with the drilled lubricant hole.
- Fit Walkerseles that have radial ports in the base (available to order) that allow lubricant to pass to the lip (see diagram below).
- When it is impractical to machine an annular groove in the housing, the groove can be incorporated in the seal backs (available to order). For this the seal section must be a minimum of 12.5mm (½ inch) in width.
- In both these cases, please discuss your applications with our Technical Support Team before metal cutting. We may be able to suggest a better alternative.

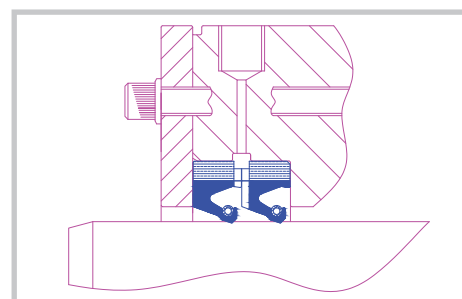

Housing with annular groove, plus seals with radial ports.

Operational considerations

Eccentricity limits

A worn or misaligned shaft/bearing assembly requires lip seals that can 'follow' the shaft by the amount it is offset.

The highly flexible lips of many Walkersele® material/design combinations will cater for certain levels of eccentricity, dependent on seal diameter and shaft surface speed.

The following eccentricity graphs apply only to 'endless' Walkerseles and **Walkersele OSJ-2** applications (see pages 22 - 23) as split-type seals may tend to open at the abutted joint when shaft offset is severe. Please discuss with our Technical Support Team any applications that involve known eccentricity: also note that modified retaining plates and/or lip support plates may be needed.

Limits of eccentricity: endless M1/D6 Walkersele®

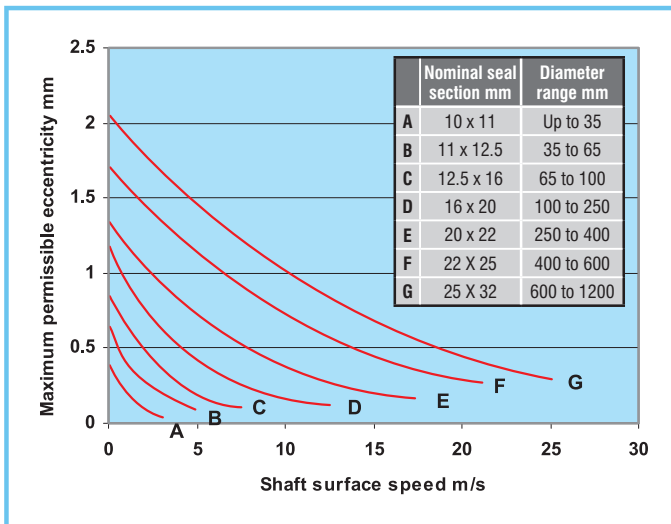

Limits of eccentricity: endless M1/D7 Walkersele®

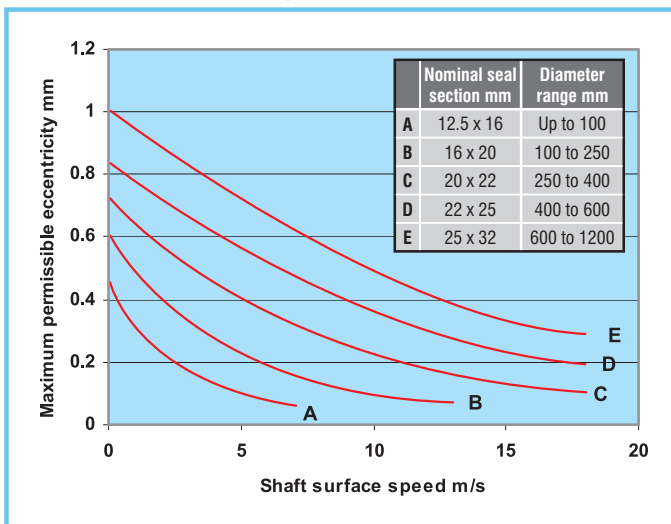

Lip support plates

A lip support plate is typically used with a Walkersele® D6 profile to increase the pressure differential rating to 200kPa/2bar (29psi).

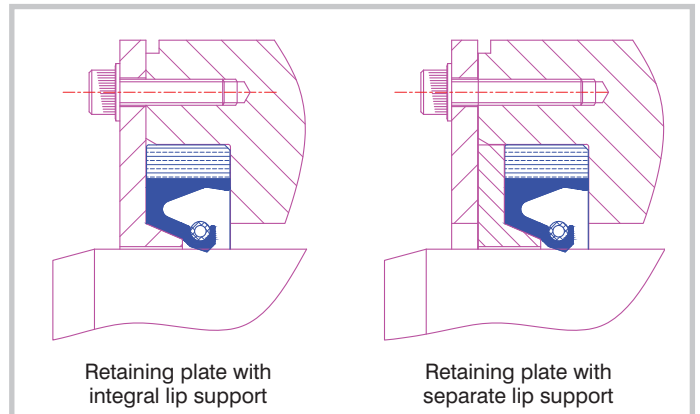

This arrangement is sometimes preferred over a Walkersele D7 profile — rated at 400kPa/4bar (58psi) — when:

- The lower lip loading of the D6 profile is required.
- The normal operating pressure and other conditions are within the limits for a D6, but the seal has to cater for periods when the pressure can increase up to 200kPa/2bar (29psi).
- Housing space is not limited, allowing both the Walkersele D6 plus lip support plate to be accommodated.
- There is no danger that any eccentricity will permit the lip support plate to make contact with the shaft.

Lip support plates are supplied to order. Our preferred materials are phosphor bronze, brass, aluminium, mild steel, and stainless steel.

Shaft features — general requirements

For long service life with a Walkersele®, the shaft area beneath the seal lip should offer the following:

- Sufficient surface hardness to resist wear.
- Surface texture that does not abrade the seal lip.
- Surface finish that will support a lubricant film — typically oil, or an oil/water emulsion or mixture in marine applications.
- Stable surface structure: eg, if coated, an adequate thickness of non-porous coating that is correctly applied, on a substrate that can support the dynamic working conditions.
- Thermal conductivity to dissipate heat away from seal lip.

Operational considerations

Shaft surfaces

The sealing area of a shaft should have a fine ground finish of 0.2 to 0.8µm Ra (8 - 32µ inch CLA) for the majority of Walkersele® applications.

Where higher speeds are involved — ie, in excess of 8m/s (1575fpm) — we recommend an improved finish of 0.2 to 0.4µm Ra (8 - 16µ inch CLA).

In all cases, the shaft sealing area must be plunge ground and free from machining marks, dents, burrs, scratches and single-pass grinding witness patterns.

Providing that lubrication is adequate and free from abrasive content, unhardened mild steel shafts will generally give satisfactory results under normal operating conditions. However, a harder shaft material is recommended for applications where lubrication is poor, abrasives are present, or speed and pressure conditions are arduous.

Shaft hardness

A shaft hardness of 40-50 HRC (Rockwell C) is generally acceptable for long-term Walkersele® operation. However, where shaft wear has to be kept to the absolute minimum — particularly with high speed, abrasive or pressurised applications — a minimum shaft hardness of 60 HRC is recommended.

When necessary, we recommend that nitrogen case hardening (nitriding) treatment be applied to certain types of steel shaft or shaft sleeve to provide about 0.5mm (0.02 inch) depth of hardened surface to around 1100 VPN (68 HRC).

Other methods of hardening the shaft surface include the application of thin dense chrome or tungsten carbide. For specific recommendations please contact our Technical Support Team.

Ceramic shafts

Albeit tough and resilient, ceramic shafts are usually abrasive and thermally insulating: as such, they should be avoided where possible. If they cannot be avoided, then the higher temperature grades of Walkersele® material, or those with better heat dissipation qualities, should be used.

Please consult our Technical Support Team for recommendations on such applications.

Housing surfaces

A fine machined finish, free of dents and scratches, is recommended for the housing bore.

All Walkerseles now have elastomeric or elastomer-proofed fabric backs and are very unlikely to damage the housings during installation, operation or removal. Metal cased seals, however, can present problems that possibly lead to housing damage during installation and/or removal when the fit is tight.

The elastomeric back of a Walkersele® presents an efficient sealing surface to the housing that prevents the by-pass of bearing lubricant or external fluid media. Walkerseles are designed to be a compression fit in their housings; therefore circumferential compression on the outside of the seal, or axial compression on the depth of the seal for retained units, provides for complete fluid sealing around the back.

The flexibility of Walkersele backs also gives them greater tolerance to slight housing imperfections — eg, ovality, damage and wear — than is possible with a metal cased seal.

Walkersele® storage

Like other precision manufactured fluid seals, Walkerseles should be stored in a cool, dark and dry place. They should be laid flat — NOT tied together with string or wire, or suspended from hooks, as this can impair the sealing efficiency of their lips.

Please refer to BS ISO 2230 *Rubber products — Guidelines for storage*.

Other rotary seal types

In addition to our Walkersele® range of lip seals, we also supply other types of well-proven seal for rotary shaft applications.

End face seals or V-rings

These flexible lip seals fit on a shaft and seal axially against a counter face — such as a roller bearing face, shaft collar or thrust washer.

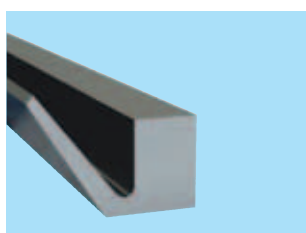

V-ring Type 41

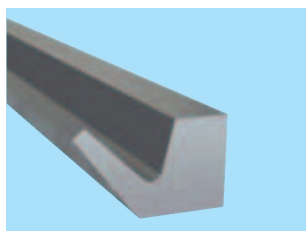

V-ring Type 78

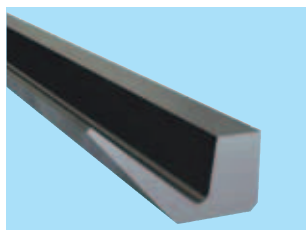

V-ring Type 99

Special features

- Well-proven designs.
- Reliable sealing against splash grease, oil and water, as well as dust and dirt.
- Low friction running.
- No running-in period required.

Availability

Standard seals: All sizes and designs of V-ring are readily available in commercial grades of elastomer; the standard grade being nitrile (NBR) of 70 IRHD (70 Shore A).

Non-standard seals: End face seals/V-rings to non-standard sizes, or in high performance elastomers to match specific duties, are in-house manufactured to order.

Please contact us to check mould availability. Where we have a suitable tool, your seal will be supplied on short delivery time without tooling charges. New tools are swiftly made; in these cases a tooling charge will be applied.

Metal cased lip seals

We supply a range of competitively priced seals to suit housings to ISO 6194 in over 500 combinations of design and size, in standard materials.



Materials

These seals are supplied with nitrile (NBR) lips as standard, with other elastomers available to suit specific working conditions. The cases and spring materials are supplied in carbon steel as standard, with stainless steel available on request.

Availability

All standard sizes and designs are readily supplied. Please contact us before placing your order, especially if non-standard types are required.

James Walker in action



Customer support at every level

When you select Walkersele®, or any of our sealing products, you immediately get the full expertise of James Walker on your side — wherever you may be in the world.

We aim to supply you with the very best

- Customer service
- Technical support
- Fluid sealing products
- Delivery
- After sales service.

Our Customer Support Centre leads the industry with its high technology service to many thousands of customers worldwide.

On-site technical advice comes from our highly experienced field engineers and industry sector specialists — backed by the materials technologists, chemists, R&D engineers and test laboratory staff at James Walker Technology Centre. Together, they have the knowledge and technical facilities to solve virtually any fluid sealing problem for our customers.

User training is another important service we provide. Our specialists regularly host sessions to instruct plant engineers and designers in the selection and installation of our products.

Worldwide network & supply

An integrated network of James Walker companies and official distributors covers over 100 countries. This is supported by a secure web-based and highly developed logistics operation to give you surety of supply for your JIT regimes, normal maintenance schedules, and emergency breakdowns.

Our automated warehouse holds over 200,000 types and sizes of different sealing products, ready for same-day despatch.



If we do not stock the Walkerseles you need, we can supply them within days — rather than weeks. This we achieve by compounding our elastomers in-house, and operating flexible manufacturing systems at our production plants.

When necessary, production time-scales can be reduced to just hours to help you bring a process line back into operation, or enable a ship to continue its journey.

In addition, our Walkersele field engineers can bring the seals with them to help your maintenance staff fit them correctly. This is particularly valuable when a Walkersele OSJ-2 is fitted and On-Site Joined for the first time by your own engineers.

Production facilities

Our manufacturing plants for elastomeric seals are located in the UK, USA and Australia. These, together with other global production facilities, ensure that we provide customers with top quality engineered solutions for their sealing problems.

In-house facilities include:

- Compression moulding to 2.2m (87 inch) diameter in a single operation, with one of Europe's biggest precision presses.
- Compression vacuum moulding to 2.1m (83 inch) diameter in a single operation.
- Continuity moulding with no joins, to unlimited diameters, for a selection of profiles.
- Special mould-joining technique for producing elastomeric components to unlimited diameters.
- Injection moulding to 500mm (19.7 inch) diameter.
- Transfer moulding.
- CNC centres for machining elastomers, engineering plastics, metal components and mould tools.
- Batch compounding of over 300 elastomer grades, with interlocked energy, time and temperature control for QA traceability.

James Walker in action

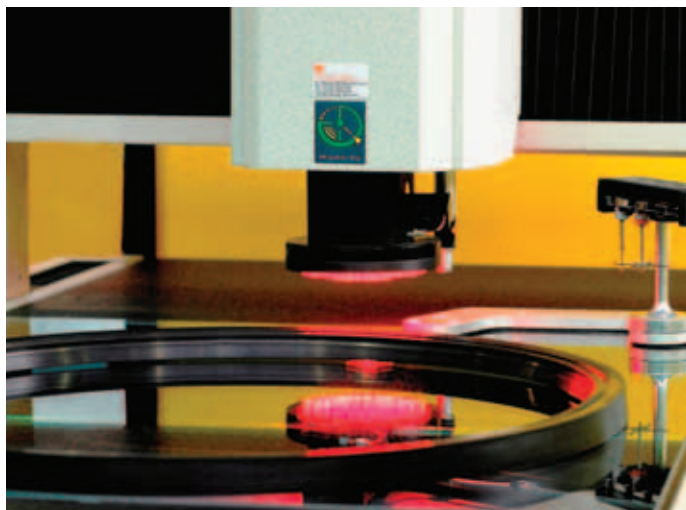

Quality standards

Our quality standards are third-party registered to ISO 9001 and AS/EN 9100. We are also certified to OHSAS 18001 and ISO 14001. In addition, we are regularly assessed and quality approved by a wide range of industry bodies including multinational corporations, utilities and government organisations.

We hold test equipment for all relevant ISO, BS, ASA, API, ANSI, DIN, DTD and NATO standards. Certificates of conformity are supplied on request, and a BS ISO 2230 compliant package is offered as standard, providing data on inspection, recording procedures and storage of products made from vulcanised and thermoplastic rubber.

We always select the best raw materials for each product, and use advanced manufacturing techniques with strict quality control and traceability at every stage — regardless of any release certification requirements. Our manufacturing process culminates in an exacting inspection procedure for the finished product. Stockholding and distribution facilities meet similar exacting standards.

In addition to our in-house test laboratories that verify our materials and products, we regularly commission independent test houses across the world for third-party certification to international, national and industry standards,

Material Safety Data Sheets (MSDS) relating to all our products are available on request.



Research & development

Our materials and product development programmes have continued unceasingly since the 1880s. They started when our founder, Scottish engineer James Walker, perfected an innovative steam packing that proved vital to the success of the high-efficiency steam engines that powered mankind into the 20th century.

Today, our technologists and laboratory staff deliver new materials, products and manufacturing techniques to improve the sealing efficiency of existing industrial plant and equipment — and meet the demands of tomorrow's systems that are still at the conceptual stage.

The objectives of our R&D activities are to provide industry with fluid sealing systems that offer:

- Longer maintenance-free operating life.
- Faster and easier installation, to reduce plant downtime.
- Improved sealing integrity.
- Ability to work at higher speeds, greater pressures, and extremes of temperature.
- Greater resistance to chemical attack and abrasive wear.
- Energy savings, through reduced break-out and dynamic friction.

Features such as our Walkersele® OSJ-2, Ultraglide, Supaglide, Millglide, Walkersele Aflas®, Walkersele® D8 design, Walkersele® cartridges, and a multitude of custom-designed products, prove the success of our programmes for rotary lip seals in recent years.

We also work on joint venture research programmes with other organisations in the European Sealing Association — of which we are a founder member — and sponsor high-level research in partnership with research institutes and leading users of sealing technology.

Industry-wide applications

Walkersele® applications

Our range of Walkersele® radial lip seals has earned an enviable reputation worldwide for sealing efficiency and long maintenance-free operation.

Here is a selection of the many sectors where plant and equipment operators rely on Walkersele's ability to keep the wheels of industry turning safely and reliably — year-in and year-out.

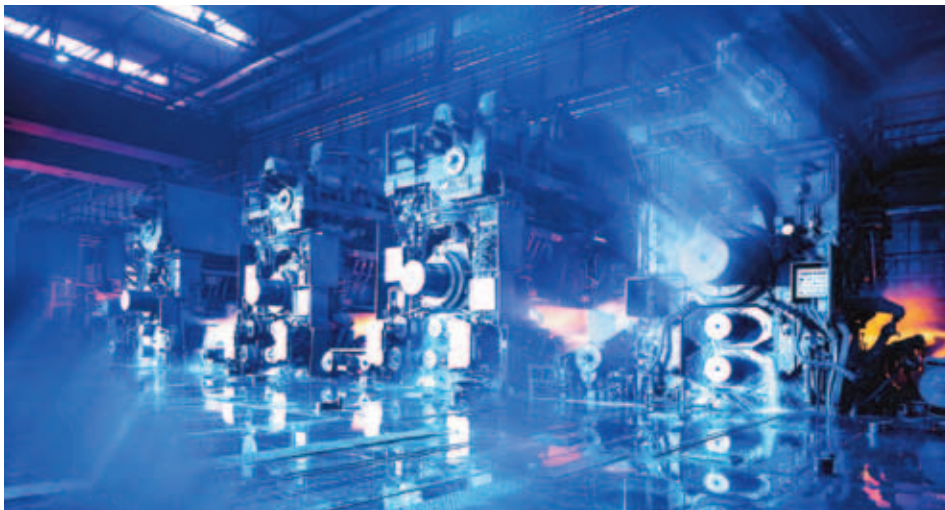

Photo courtesy of Siemens VAI

Metallurgical sector

- AGC capsules
- Casters
- Coating lines
- Cold mills
- Coil boxes & down coilers
- Coilers & reelers
- Extrusion presses
- Finishing mills
- Forging presses
- Hot rolling mills
- Overhead cranes — gearboxes
- Plate mills
- Strip mills
- Temper mills
- Universal mills — scale breakers, roughers, edgers, billet, bloom & slab.

Mineral extraction & processing

- Cement mills
- Conveyors
- Drag lines
- Mixers & grinders
- Rock crushers
- Rotary kilns
- Winding gear.

Power generation

- Coal pulverisers & ball mills
- Diesel plant
- Generator sets
- Hydroelectric plant — water turbines & dam gate bearings
- Steam turbines
- Wind turbines.

Marine

- Bow thrusters
- Bulkhead seals
- Crane drums
- Dredging plant
- Gearboxes & transmission systems
- Power plant
- Rudder posts
- Shaft bearings
- SRP swivel joints & shafts
- Stabilisers
- Stern glands.

Processing sector

- Centrifuges
- Chemical pulping lines
- Dry cleaning machines
- Extractor drums
- Mixing vessels.

Pulp & paper mills

- Calenders
- Chippers
- Debarkers
- Digesters
- Dryers
- Felt rolls
- Head boxes
- Press rolls
- Screening
- Section rolls
- Washers.

Food & pharmaceuticals

- Conveyors
- Cutters
- Grinders
- Mixers.

Construction

- Tunnel boring machines.

Land transport

- Rail traction systems.

Manufacturing industry

- Machine tools.

Water industry

- Filter beds.

Information

Alphabetical index of products & materials

	Page		Page
Aflas® — tetrafluoroethylene-propylene (FEPM)	14	Walkersele® Cartridges	24
Customised designs	19-20	Walkersele® D1 — original design	17
End face seals or V-rings	42	Walkersele® D4 — for slow rotary duties	17
Endless-type Walkerseles	27	Walkersele® D5 — compact design	17
M1 — NBR material	12	Walkersele® D6 — most popular design	15
M5 — IIR material	12	Walkersele® D7 — pressure resistant	16
M6 — NBR material	12	Walkersele® D8 — for marine propulsion and processing	16
M8 — FKM material	12	Walkersele® Long Lip	26
M9 — FKM material	12	Walkersele® M1/D6 standard range — inch & metric	28-29
M11 — NBR material for marine and power train duties	12	Walkersele® M6/D6 standard range — inch & metric	30-32
M12 — NBR material	13	Walkersele® OSJ-2 for On-Site Joining	22-23
M13 — NBR material	13	Walkersele® Shaft Sleeves	24
M22 — HNBR material for wind turbines	13	Walkersele® Shallowback designs	26
Metal cased lip seals	42	Walkersele® SpringCover	25
Millglide — HNBR material for rolling mills	13	Walkersele® SpringSafe	25
Spacer rings	24	Walkersele® TBMS — for tunnel boring machines	18
Split-type Walkerseles	27	Walkersele® with Dust Lip	25
Supaglide — HNBR material for rolling mills	13	Walkersele® with Ports & Grooves	26
Ultraglide — optimised HNBR material for long life	14		

Trademark acknowledgements

James Walker acknowledges the following trademarks as mentioned in this document. All other names bearing the ® symbol are registered trademarks of James Walker.

Aflas® Asahi Glass
Inconel® Special Metals Corporation

General information

Health warning: If PTFE or fluoroelastomer (eg, FKM, FFKM, FEPM) products are heated to elevated temperatures, fumes will be produced which may give unpleasant effects, if inhaled. Whilst some fumes are emitted below 250°C from fluoroelastomers or below 300°C from PTFE, the effect at these temperatures is negligible. Care should be taken to avoid contaminating tobacco with particles of PTFE or fluoroelastomer, or with PTFE dispersion, which may remain on hands or clothing. Safety Data Sheets (SDS) are available on request.

Information in this publication and otherwise supplied to users is based on our general experience and is given in good faith, but because of factors which are outside our knowledge and control and affect the use of products, no warranty is given or is to be implied with respect to such information. Unless governed by type approval or contract, specifications are subject to change without notice. Statements of operating limits quoted in this publication are not an indication that these values can be applied simultaneously.

To ensure you are working with the very latest product specifications, please consult the relevant section of the James Walker website: www.jameswalker.biz.

Environmental statement: This brochure is manufactured using advanced environmentally friendly technologies and follows the strict environmental standard BS EN ISO 14001. Made from chlorine-free pulp (ECF) with post-consumer recycled fibre obtained from sustainable wood forests, and printed using vegetable-based inks, by Binfield Printers Ltd. For those who wish to reduce further their impact on the environment, this publication is also available as a PDF from: www.jameswalker.biz.

Technical guides

These guides give detailed technical information on the products and services covered in this publication. Please ask for your printed copies, or visit our website www.jameswalker.biz where they can be downloaded in pdf form.

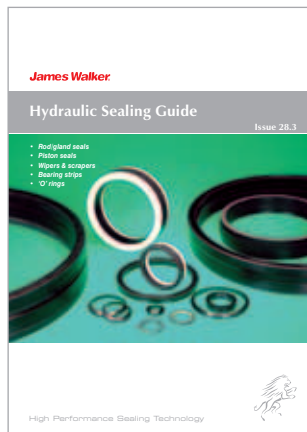

Hydraulic seals

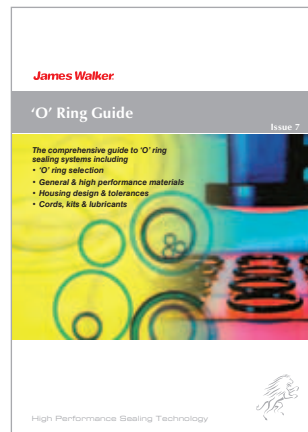

'O' Rings

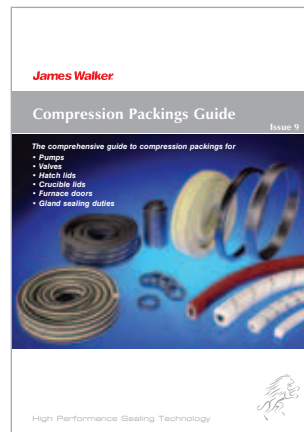

Compression packings

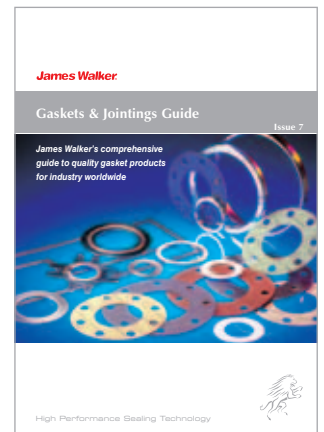

Gasket & jointings



PTFE & thermoplastic seals

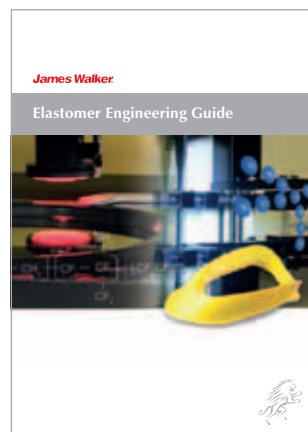

Elastomer engineering



Expansion joints & bellows

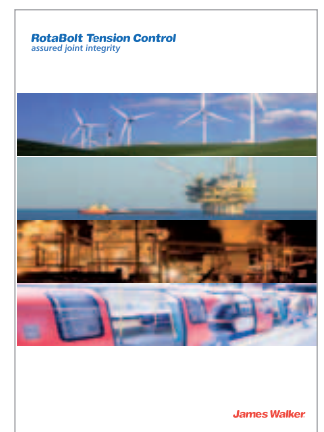

RotaBolt® tension control

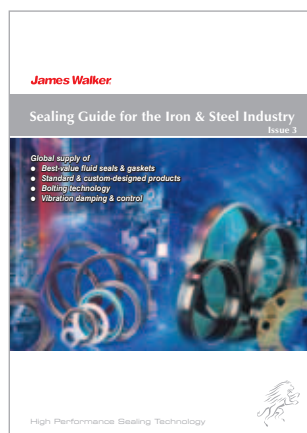

Iron & steel industry guide

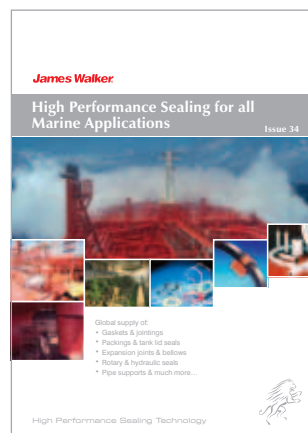

Marine industry

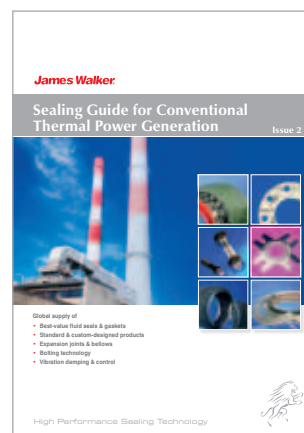

Conventional power generation

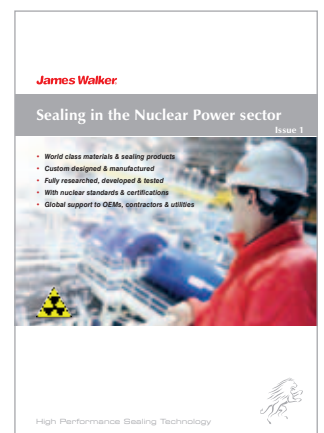

Nuclear power generation

James Walker®

James Walker worldwide support & distribution

James Walker Asia Pacific

Tel: +65 6267 4788
Fax: +65 6267 4980
Email: sales.sg@jameswalker.biz

James Walker Australia

Tel: +61 (0)2 9721 9500
Fax: +61 (0)2 9721 9580
Email: sales.au@jameswalker.biz

James Walker Benelux

(Belgium)
Tel: +32 3 820 7900
Fax: +32 3 828 5484
Email: sales.be@jameswalker.biz
(Netherlands)
Tel: +31 (0)186 633111
Fax: +31 (0)186 633110
Email: sales.nl@jameswalker.biz

James Walker Brasil

Tel: +55 11 4392 7360
Fax: +55 11 4392 5976
Email: sales.br@jameswalker.biz

James Walker China

Tel: +86 21 6876 9351
Fax: +86 21 6876 9352
Email: sales.cn@jameswalker.biz

James Walker Deutschland

Tel: +49 (0)40 386 0810
Fax: +49 (0)40 389 3230
Email: sales.de@jameswalker.biz

James Walker France

Tel: +33 (0)437 497 480
Fax: +33 (0)437 497 483
Email: sales.fr@jameswalker.biz

James Walker Iberica

Tel: +34 94 447 0099
Fax: +34 94 447 1077
Email: sales.es@jameswalker.biz

James Walker Inmarco (India)

Tel: +91 (0)22 4080 8080
Fax: +91 (0)22 2859 6220
Email: info@jwinmarco.com

James Walker Ireland

Tel: +353 (0)21 432 3626
Fax: +353 (0)21 432 3623
Email: sales.ie@jameswalker.biz

James Walker Italiana

Tel: +39 02 257 8308
Fax: +39 02 263 00487
Email: sales.it@jameswalker.biz

James Walker Mfg (USA)

Tel: +1 708 754 4020
Fax: +1 708 754 4058
Email: sales.jwmfg.us@jameswalker.biz

James Walker New Zealand

Tel: +64 (0)9 272 1599
Fax: +64 (0)9 272 3061
Email: sales.nz@jameswalker.biz

James Walker Norge

Tel: +47 22 75 75 00
Email: sales.no@jameswalker.biz

James Walker Oil & Gas (USA)

Tel: +1 281 875 0002
Fax: +1 281 875 0188
Email: oilandgas@jameswalker.biz

James Walker South Africa

Tel: +27 (0)31 304 0770
Fax: +27 (0)31 304 0791
Email: sales.za@jameswalker.biz

James Walker UK

Tel: +44 (0)1270 536000
Fax: +44 (0)1270 536100
Email: sales.uk@jameswalker.biz

James Walker UK Ltd

Customer Support Centre
Gawsworth House, Westmere Drive
Crewe, Cheshire CW1 6XB, UK
Tel: +44 (0)1270 536000
Fax: +44 (0)1270 536100
Email: sales.uk@jameswalker.biz

www.jameswalker.biz

